

## TALK TO US ABOUT OUR PRODUCTS

- PINEHAVEN TIMBER GARDEN SHEDS
- PINEHAVEN KIDS CUBBIES AND PLAYHOUSES
- PINEHAVEN COURTYARD CUPBOARDS
- PINEHAVEN GARDEN ARCHWAYS AND PERGOLAS
- PINEHAVEN FENCE AND TRELLIS PANELS
- PINEHAVEN CLIMBING FRAMES
- PINEHAVEN PLANTER BOXES

## CONTACT US

- By asking about our products at your nearest DIY or gardening store
- [www.pinehavensheds.co.nz](http://www.pinehavensheds.co.nz)
- email: [sales@pinehavensheds.co.nz](mailto:sales@pinehavensheds.co.nz)
- 1 The Esplanade, Petone, Lower Hutt



[www.pinehavensheds.co.nz](http://www.pinehavensheds.co.nz)

**PINEHAVEN**  
GARDEN PRODUCTS

# PINEHAVEN SHEDS

## Assembly Instructions

FOR ST ARNAUD, CRAIGIEBURN, BEN MCLEOD, HAAST

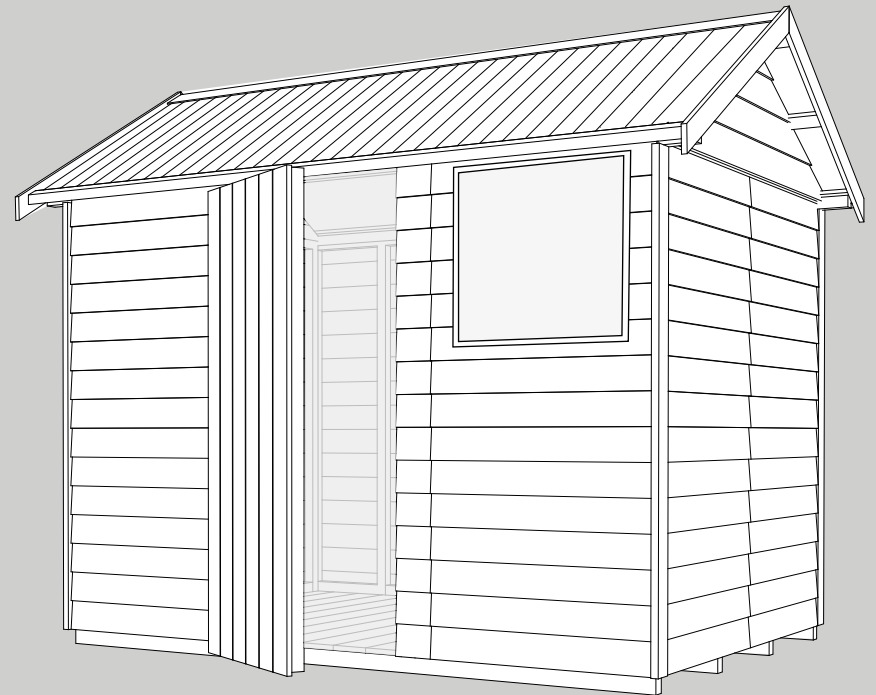

# Pinehaven Shed Assembly Instructions

Please read through the following instructions in full before commencing assembly.

---

## TOOLS REQUIRED:

Ground levelling tools, step ladder, tape measure, spirit level, hammer, pozi-drive screw driver, 5/16" hex drive bit, electric drill and pop riveter.

## COMPONENTS:

See separate check list and floor plan provided.

## SITE PREPARATION:

Your ground surface should be compacted to a 'firm' level surface. ensure that no water will pond on the site. Your shed can be assembled on a reinforced concrete pad or a treated timber floor.

---

## DOOR ASSEMBLY

### TOP DOOR STOP

Position the top door stop (760mm long x 50mm x 50mm) into position flush with the inside edge of the top plate using two 38mm screws provided. A snug fit will give accurate positioning of the door assembly.

Note: If you have ordered double doors, your door stop will be 45mm x 45mm x 1520mm long.

### HINGES

Fix the hinges to the door. Position the two door hinges to the notched door frame and fasten using the 38mm screws provided.

Position the door to the wall panel ensuring adequate top and bottom clearance for opening and closing.

Fasten the hinges to the door frame wall panel using the 38mm screws provided. Hint: Fix one screw to each of the hinges and check the clearance prior to fixing the remaining screws.

### PADBOLT

Position the pad bolt and hasp and fix with the 38mm screws provided.

### LOCKING HANDLE

If you have selected a locking handle in your shed kit, you will find the door has pre-drilled holes. Position and fix with the screws provided

---

## STAINING AND PAINTING THE SHED

We recommend all nail holes are stopped with a putty or filler. We recommend a stain or paint, preferably in light colours for protection and in order to deflect heat from the shed. **An oil based stain or a water based paint is recommended.**

The life of your shed will be extended by re-applying stain or paint as required from time to time and occasional washing of the roof and cleaning of the gutters and debris.

## ROOF ASSEMBLY

### TOP ROOF FLASHING

Remove the protective film from the 'V' shaped flashing. There are two or more flashing sections for each shed kit and these should be overlapped so as to butt to the fascia boards. (See Fig 17).

Fix into position by drilling 3.3mm clearance holes through the flashing and into every second roof sheet 'top rib'. Fix into position using the pop rivets provided. Note it is best to drill and fix one rivet at a time.

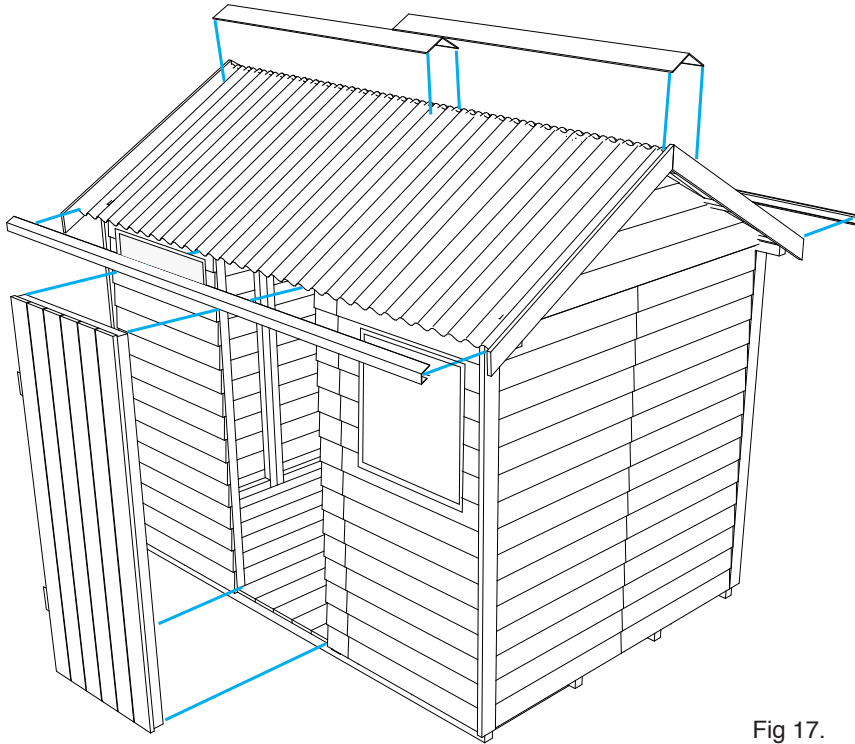

Fig 17.

### GUTTERS

Remove the protective film from the "U" shaped gutter sections. Note the gutter profile has a 'wide' and 'narrow' edge. The 'wide' edge is fixed to the top edge of the roof enabling the 'short edge' to hang under the roof sheet. (See Fig 17).

Fix into position by drilling 3.3mm clearance holes through every second top roof rib and fixing with the rivets provided. Brush or wash the roof to ensure no swarf (steel filings) remain from drilling the holes for the flashings.

## FLOOR ASSEMBLY

### TIMBER FLOOR: (Optional)

Lay the bearers parallel and at equal spacing apart. Lay one floor board across each end and nail flush to the outside edge of the bearers. (See Fig 1).

Note: The bearers always run the length of the shed, in alignment with the gable roof ridge.

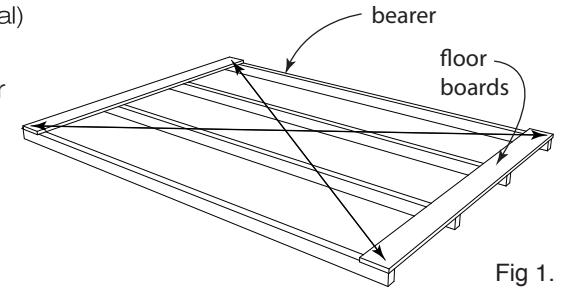

Fig 1.

'Square' the floor by measuring from opposite corner to opposite corner and adjust until both diagonal measurements are equal. At all times through this process the shed levels should be checked.

Use packers or 'infill' material to ensure the floor remains level. Position the remaining floor boards and depending on the spacing require, you may need to cut one board down its length.

A tight fit can be achieved by positioning the boards and then 'pressing' them into position. (See Fig 2).

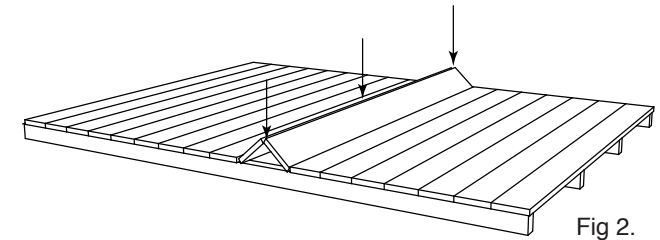

Fig 2.

Mark a line to which each floor board will be fixed to the bearers. Fix two 60mm nails per board and bearer cross point. (see Fig 3). Note: Top plate can be useful as a ruler.

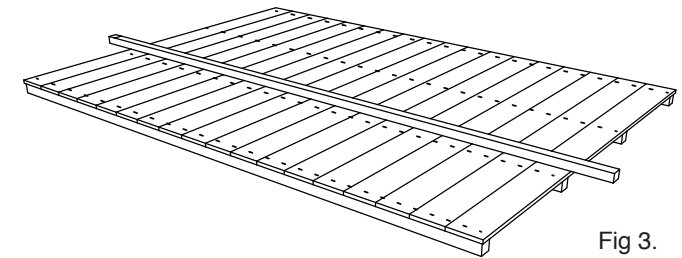

Fig 3.

### CONCRETE PAD: (Optional)

Construct formwork to allow a base size which should be 5mm less than the floor dimensions outlined in the 'Pinehaven Floor Plan'. This will ensure that the shed will overhang the pad by approximately 5mm around the shed perimeter. The pad should be at least 75mm deep and reinforced with steel mesh & moisture barrier.

**Note:** Do not fix the shed to the pad until the concrete has cured for at least four days.

## WALL ASSEMBLY

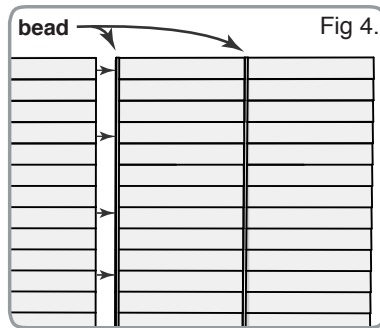

### WALL PANELS

The shed kit will comprise a combination of three types of panels. These are “left bead”, “right bead” and “no bead.” Note the detail of wall plan layout is shown in the schematic floor plan.

**Note:** When two panels are screwed together (except at a 90° angle) there should always be a ‘bead’ where the panels butt together. (Fig. 4).

Note also that the front and rear walls panels sit outside the gable end wall panels. Refer to schematic floor plan. Stand the wall panels in the correct sequence as shown schematically on the Pinehaven checklist.

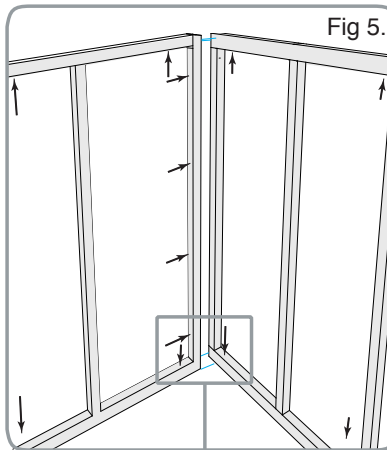

### CLEARANCE HOLES

Use a 4mm bit to drill four equally spaced clearance holes through one side of the panel stud. (Fig. 5).

Drill two clearance holes through the bottom of the wall panel in preparation to fix to the floor.

Drill two clearance holes on an angle through the top of the wall panel in preparation to fix to the roof assembly. Pre-position 75mm screws into each of the clearance holes.

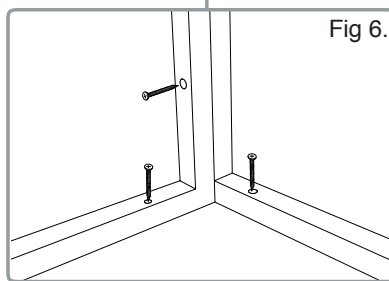
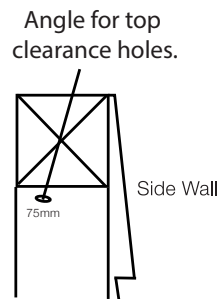

## ROOF ASSEMBLY

### ROOFING SHEETS

Place the first roofing sheet against the fascia board noting the rib pattern. (See Fig 15) Ensure that all sheets are “square” to the fascia and purlins.

If a “half sheet” is provided, you will note this will not be cut evenly along one side. A neat finish can be achieved by ensuring the uneven edge laps under the adjoining sheet.

Flip the last sheet on each side so as to finish with the same edge as you started with, as shown in Fig 15.

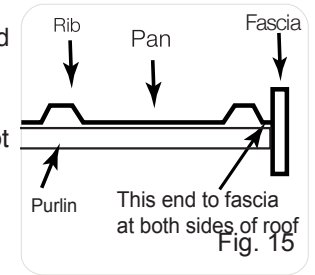

### ROOF CLOUDS

Using the 25mm “flat head” galvanised clouts provided, fix the roofing sheet to the top edge of the top purlin.

**Note:** these clouts are fixed through each “pan” of the roof sheet. (See Fig 16). **Do not use tek screws on this top edge.**

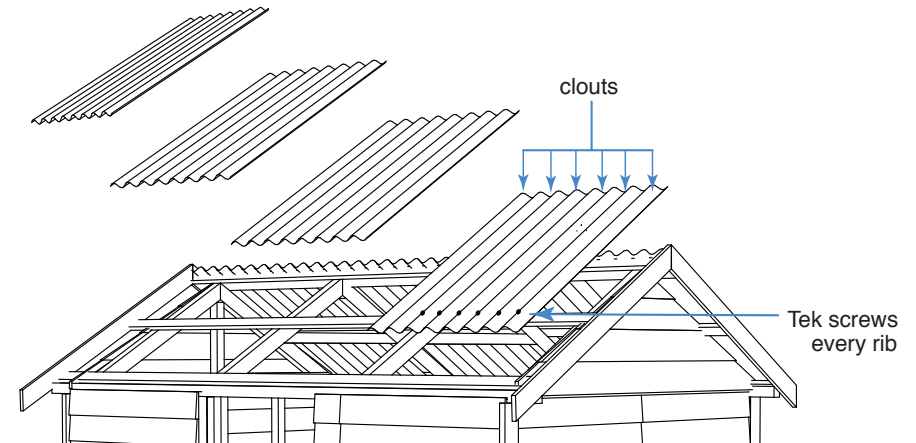

### TEK ROOF SCREW

Included in the kit are 35mm self-tapping tek screws. Using a 5/16” hex drill bit, fix a line of tek screws along the **bottom edge** through every rib and into the top plate. This is approximately 130mm from bottom edge of sheet.

**Hint:** Position screw, tap lightly with a hammer before screwing through.

**Hint:** It can be very useful to use a string line along this edge to maintain a straight line of screws.

Repeat this process for the other side.

**DO NOT USE** screws on the top edge of the roofsheet where clouts should be used.

## ROOF ASSEMBLY

### ROOF PURLINS

There are four purlins in the shed kit. Position the first purlin on top of one side of the gable and trusses. Align the purlin with the side top plate and fix with the 60mm nails provided.

Position the second purlin midway between the first purlin and the side top plate. (See Fig 14).

Ensure the side top plates and purlins are all in alignment as the roof fascia boards will be fixed to the ends of this assembly.

Position the third and fourth purlins on the opposite side of the shed.

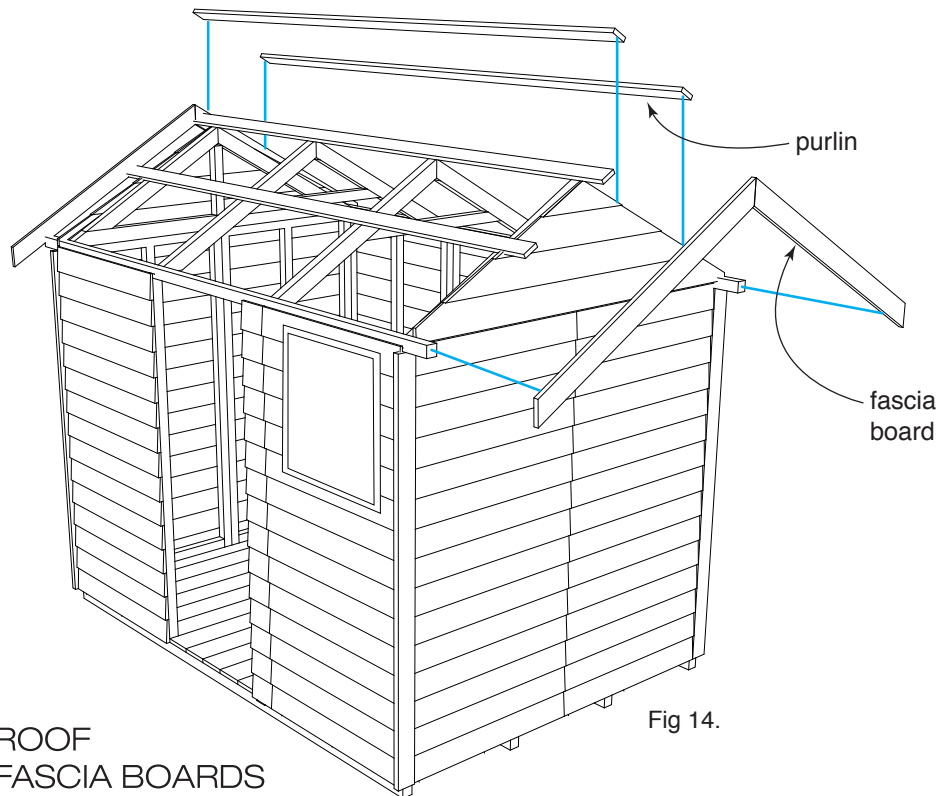

Fig 14.

### ROOF FASCIA BOARDS

Match the four fascia boards into two pairs (band sawn face to the outside) and fix into position with 50mm nails provided. (See Fig 14). The fascia boards should sit approximately 10mm above the purlins.

## WALL ASSEMBLY

**Note: Check your unique floor plan for layout. This may differ to the configuration in this assembly.**

Run a bead of sealant down one side edge of the panel before screwing to the adjacent panel. Pre-position 75mm screws into each of the clearance holes. Align the first panel with the second and holding firmly screw the two panels together. (A 'G-Clamp' will assist but is not critical). Note: Generally it is best to start with an end and side panel enabling the panels to easily stand upright.

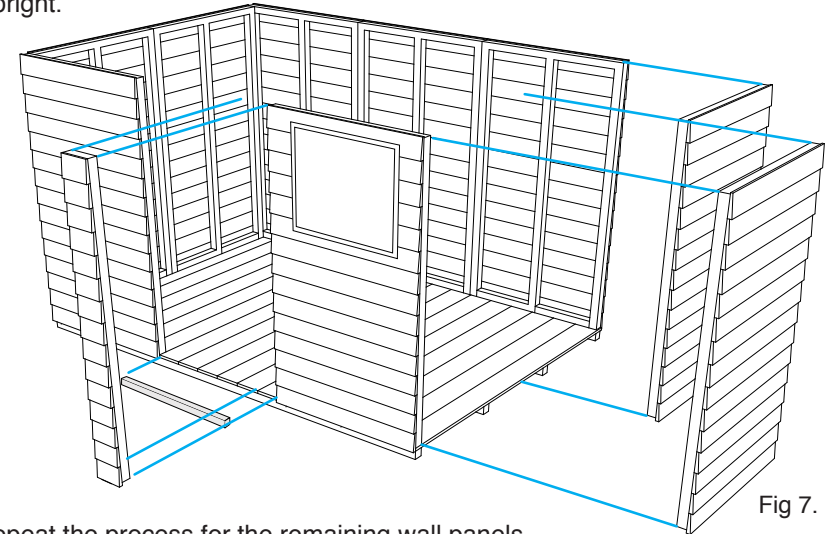

Fig 7.

Repeat the process for the remaining wall panels, making sure the panels remain flush. Work toward the door opening, noting the last panel to position is the 'door wall panel'. Use the bottom door stop as the spacer to ensure to you leave the correct gap for the door.

### FIXING TO TIMBER FLOOR

When all panels have been screwed together, centralise the wall assembly on the floor. Before fixing into position with the 75mm screws (two per panel) run a bead of sealant around the perimeter of the shed floor.

Fix the bottom door stop into position using the two 75mm screws provided. Note: Once the shed is assembled, the bottom door stop can be removed if desired.

Your shed may be fixed to a concrete pad using dynabolts, "L" brackets or "masonry pins". Drill appropriate sized clearance holes and fix into position using the instructions appropriate for the selected fixings.

**DO NOT** dynabolt the shed until you have the roof and door assemblies complete.



## ROOF ASSEMBLY

### TOP PLATES

Position one 'side top plate' on top of the side wall panel assembly. (See Fig 8 & 9).

Note the gable ends and trusses will fit inside the top plates so check for a snug fit (trusses and gable ends) before fixing the top plate into position.

Note also that the top plates will extend beyond the gable end walls by an equal distance of approximately 100mm at each end.

Screw the second top plate into position allowing for an identical alignment with the first top plate. (See Fig 9).

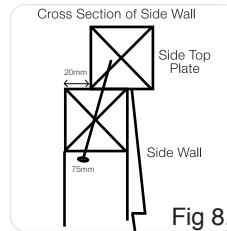

Fig 8.

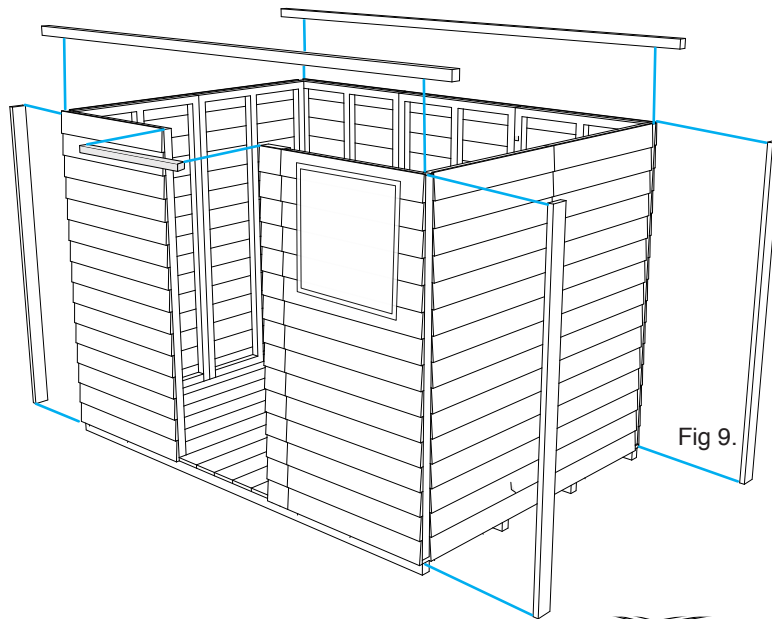

Fig 9.

### CORNER BOARDS

The shed kit has four corner boards. Run a bead of sealant along the internal edge of the four exposed corners of the shed. (Fig 10).

Fix the four corner boards using the 60mm nails provided. (See Fig 9).

Ensure each corner board fits snug to the side top plate on the upper edge.

Fit the top door stop to the top plate (Fig 9) using 2x 75mm screws.

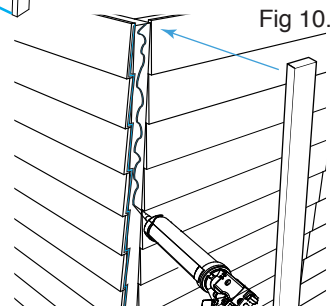

Fig 10.

## ROOF ASSEMBLY

### GABLE END TRUSS

Run a bead of sealant along the bottom edge of each gable end truss and position on top of the wall assemblies.

The truss should butt to the corner boards.

Fix into position using two 75mm screws for each wall panel. (See Fig 11 + 12).

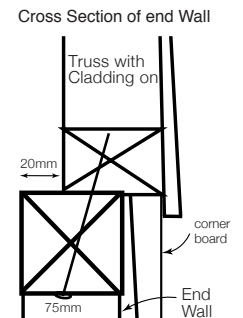

Fig 11.

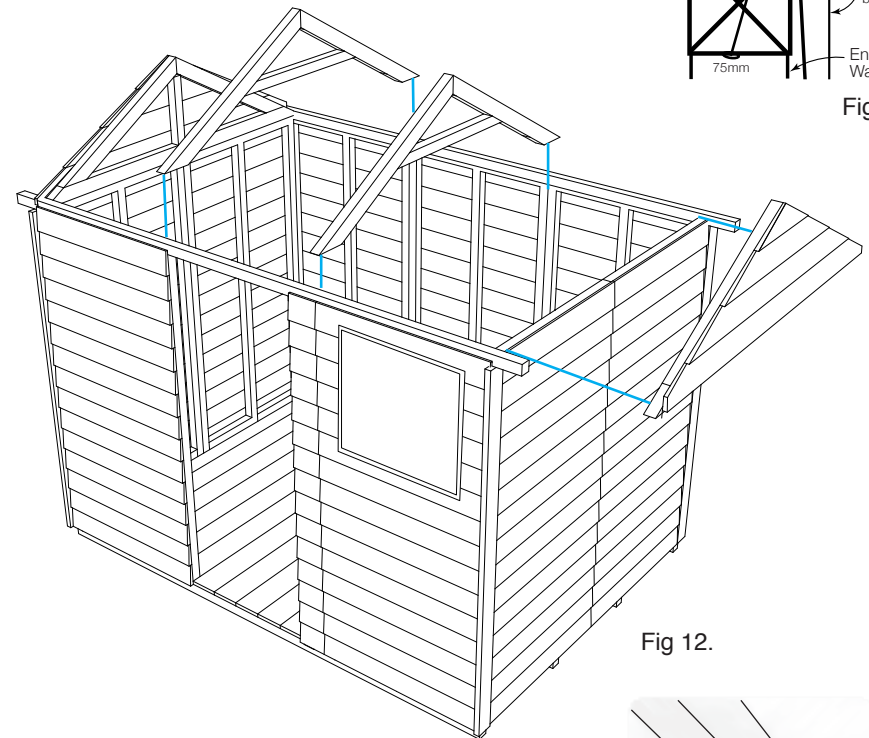

Fig 12.

### CENTRE TRUSSES

Place the centre trusses between the side top plates and at an equal distance. These will sit to the side of the join in the "wall panel assembly." (See Fig. 12 + 13). Fix from the outside of the top plate using one 75mm screw on each end of the truss.

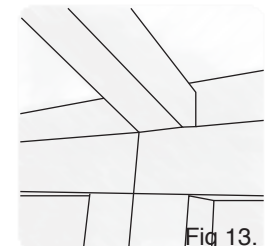

Fig 13.