

Duratuf

ASSEMBLY INSTRUCTIONS



WINDSOR

BASE SIZE: 2.400m x 1.500m

BEFORE YOU BEGIN THE ASSEMBLY PLEASE NOTE SOME IMPORTANT POINTS

TOOLS REQUIRED

- Electric / Battery Drill
- 5/16" Hex Drive Screwdriver Bit (for screwing in the Tek Screws)
- 3.5mm Steel Screwdriver Bit
- 10mm Steel Screwdriver Bit
- (If anchoring to a concrete floor) 12mm Concrete Drill Bit And Concrete Drill
- 'Square Drive' Screwdriver Bit
- Phillips Drill Bit
- Slotted Drill Bit
- Riveter
- Hammer
- Tape Measure
- Stepladder
- String Line
- Adjustable Spanner
- Spirit Level
- Hand Saw
- Caulking Gun
- Tin Snips (Left & Right Hand)
- Flat file (For The Roller Door Lock slots)
- Pipe Wrench (For Roller Door)
- Circular Saw and Jigsaw (For fitting optional timber floor only)

BEFORE YOU START

- Read all instructions right through so you understand the full process.
- Identify all parts and check quantities against the checklist before starting.
- Before assembly, remove protective film where present from all flashings and colored steel components.

SAFETY FIRST!

- Do not attempt to build your shed in high winds.
- Wear rubber coated gloves -beware of sharp edges on steel cladding and flashings.
- Protect your eyes and ears.
- Use electric power tools with care. Use a Safety Trip Switch.
- It is easier and quicker if this shed is assembled by two people. Some understanding of building is recommended and there are some processes that require handyman experience.

SELECT YOUR SITE

- Your shed must be level. Achieve this by either levelling the ground or by using blocks.
- If your shed is to be positioned on wet or damp ground, we recommend that your shed is raised up off the ground slightly.













WARRANTY REQUIREMENTS

The following maintenance process needs to be adhered to, to qualify for the steel warranty of your Duratuf Matakana shed.





- Wash all surfaces annually using a hose and soft nylon brush.
- Within 2 km of coast – wash every 3 months as above. After a storm, wash the cladding and the gutters as soon as possible to remove any highly corrosive salt deposits.
- Volcanic Ash Fallout – wash as soon as possible, removing fall-out from roof and gutters.
- Do not allow manures, chemicals or other corrosive materials to have direct contact with cladding.







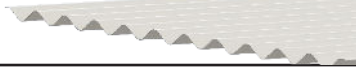
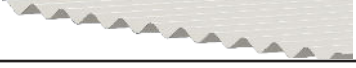



PARTS LIST

TIMBER FRAMING











DESCRIPTION	LENGTH	QTY	DIAGRAM	CHECKED
Front/Back Base Plate 45 x 45 H4 (Green)	2.400m	2		<input type="checkbox"/>
End Base Plate 45 x 45 H4 (Green)	1.500m	2		<input type="checkbox"/>
Front/Back Top Plate 45 x 45 H1 (Red)	2.400m	2		<input type="checkbox"/>
End Top Plate 45 x 45 H1 (Red)	1.500m	2		<input type="checkbox"/>
Lintel 45 x 45 H1	1.890m	1		<input type="checkbox"/>
Stud 45 x 45 H1 (Yellow)	2.250m	7		<input type="checkbox"/>
Stud 45 x 45 H1 (Yellow)	0.243m	4		<input type="checkbox"/>
Stud 45 x 45 H1 (Yellow)	1.962m	2		<input type="checkbox"/>
Top Plate Packer 70 x 45 H1	2.400m	1		<input type="checkbox"/>
Nog 45 x 45 H1	1.410m	2		<input type="checkbox"/>
Nog 45 x 45 H1	1.132m	2		<input type="checkbox"/>
Nog 45 x 45 H1	0.165m	2		<input type="checkbox"/>

CLADDING/FLASHINGS

DESCRIPTION	LENGTH	QTY	DIAGRAM	CHECKED
Back Wall Cladding Sheets	2.400m	3		<input type="checkbox"/>
End Wall Cladding Sheets	1.500m	6		<input type="checkbox"/>
Roof Sheets	1.830m	3		<input type="checkbox"/>
Front Wall Sheet	0.300m	6		<input type="checkbox"/>
Half Front Wall Sheet (390mm wide)	2.400m	1		<input type="checkbox"/>
Roller Door	1.800m	1		<input type="checkbox"/>

DESCRIPTION	LENGTH	QTY	PART#	DIAGRAM	CHECKED
Front Corner Flashing	2.435m	2	1001		<input type="radio"/>
Back Corner Flashing	2.365m	2	1002		<input type="radio"/>
Door Top Flashing	1.995m	1	1003		<input type="radio"/>
Door Head Flashing	1.800m	1	1004		<input type="radio"/>
Door Jamb Flashing	2.032m	2	1005		<input type="radio"/>
Barge Flashing	1.895m	2	1006		<input type="radio"/>
Spouting	2.525m	1	1007		<input type="radio"/>
Downpipe Cover Flashing	2.240m	1	1008		<input type="radio"/>
Fascia	2.525m	1	1009		<input type="radio"/>
Front Top Plate Flashing	2.400m	1	1010		<input type="radio"/>
Spouting End Cap	0.040m	2	1011		<input type="radio"/>

HARDWARE/ACCESSORIES









DESCRIPTION	LENGTH	QTY	DIAGRAM	CHECKED
Flathead Nails	75mm	100		<input type="radio"/>
Clouts	30mm	110		<input type="radio"/>
Rivets	7.9mm	75		<input type="radio"/>
Tek Screws	55mm	70		<input type="radio"/>
Tek Screws	25mm	185		<input type="radio"/>
75mm DPC Waterproof Tape	30m Roll	1		<input type="radio"/>
RTV Silicone		1		<input type="radio"/>
Downpipe Dropper		1		<input type="radio"/>
Downpipe Brackets		2		<input type="radio"/>
Touch up paint and brush		1		<input type="radio"/>
Downpipe	2.500m	1		<input type="radio"/>

OPTIONAL EXTRAS

CLEAR ROOF

DESCRIPTION	LENGTH	QTY	DIAGRAM	CHECKED
Clear Roof Panel	1.830m	1		<input type="checkbox"/>

PLY FLOOR

DESCRIPTION	LENGTH	QTY	DIAGRAM	CHECKED
Plywood 17mm treated	1.500m x 1.200m	2		<input type="checkbox"/>
Joists 70 x 45mm H4	2.310m	4		<input type="checkbox"/>
Joists 70 x 45mm H4	1.500m	2		<input type="checkbox"/>
Joists 70 x 45mm H4	0.440m	3		<input type="checkbox"/>
Aluminium Door Step Flashing	1.795m	1		<input type="checkbox"/>
Floor Screws	75mm	30		<input type="checkbox"/>
Floor Screws	40mm	45		<input type="checkbox"/>
Tek Screws	100mm	12		<input type="checkbox"/>

SOLID TIMBER FLOOR KIT

DESCRIPTION	LENGTH	QTY	DIAGRAM	CHECKED
Timber Floor Boards 150 x 25mm	1.500m	16		<input type="checkbox"/>
Joists 70 x 45 H4	2.400m	4		<input type="checkbox"/>
Aluminium Door Step Flashing	1.795m	1		<input type="checkbox"/>
Floor Nails	50mm	140		<input type="checkbox"/>
Tek Screws	100mm	12		<input type="checkbox"/>

DATE: / /

PACKED BY:

FOUNDATIONS

- No doubt by now you will have decided what sort of flooring base you are going to use.
- If you choose to pour a concrete floor, this is the best option as the cladding overlaps with the floor prevents the water from flowing inside the shed. Please see the details below for pouring your concrete floor.
- The second option is to install your shed on a Duratuf Timber Floor Kit. If you have one of these floor kits, please make sure that you read through the instructions fully first and proceed to build this floor prior to starting your shed. You will need to ensure that the ground is firm and flat and the floor is anchored down securely

CONCRETE BASE

BUILDING A CONCRETE SLAB FLOOR

- Prior to setting up the boxing for your concrete floor you will need to mark out the area to 300mm bigger than the size of the shed. Remove any soft soil or dirt, fill with sand or crusher dust and compact firmly to about 40-50mm below ground level.
- The concrete base should be 100mm thick around the outside, 80mm in the middle and the top of the slab should be at least 50mm above the ground line to avoid water running into your shed.
- Set up timber boxing to 2380mm x 1480mm (inside measurement of the boxing) **This is 20mm smaller than the external measurement of the shed frame** which allows a 10mm gap between the overhanging cladding and the concrete slab on all four sides of the shed.
- If you wish, place some plastic sheeting underneath the concrete to stop moisture coming through the floor.
- Now is the time to place any steel reinforcing or mesh.

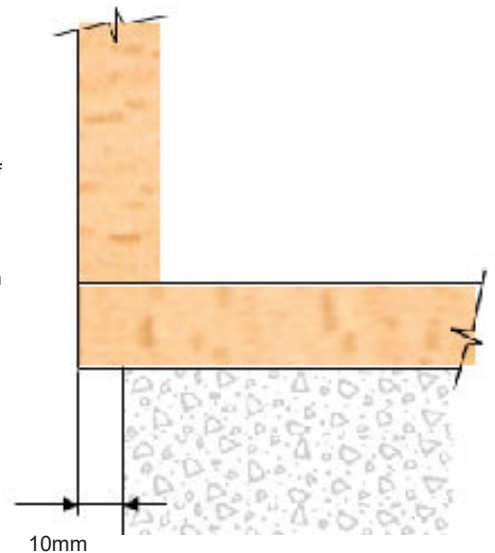

IMPORTANT - SHAPING THE FLOOR AT THE DOORWAY

To allow the water to run away from the roller door seal at the front of the shed, find the centre of the front and measure 900mm each way. This is the position of the 1800mm door and where you will slope the concrete for water runoff.

When you have poured your concrete, starting from 100mm back from the front, shape the concrete so that it slopes down 20mm below the boxing at the front.

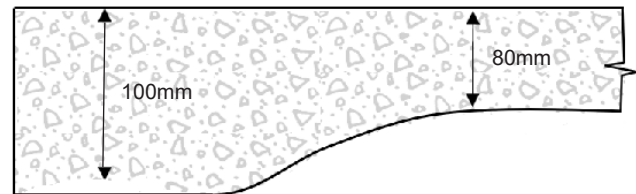

TIMBER FRAME

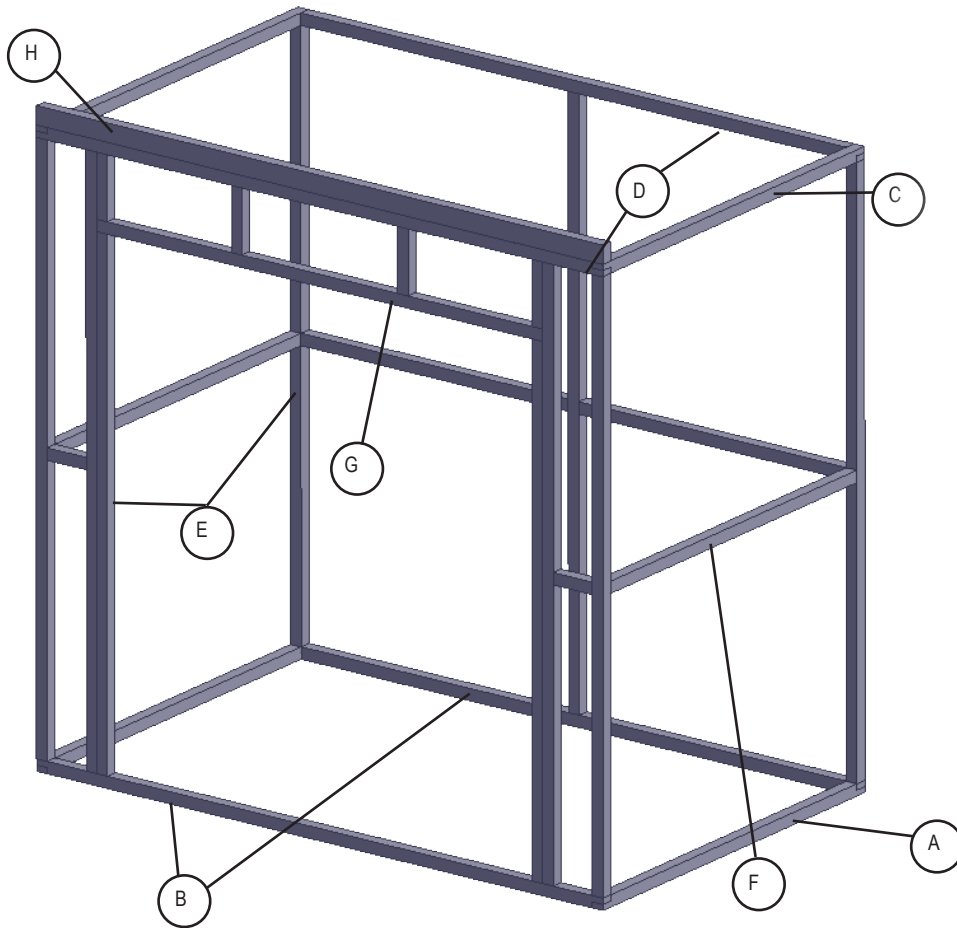

- (A) End Base Plates - 2
- (B) Front/Back Base Plates - 2
- (C) End Top plates - 2
- (D) Front/Back Top Plates - 2
- (E) Studs - 7
- (F) Nogs - 6
- (G) Lintel - 1
- (H) Front Roof Packer - 1

TIMBER FRAME - BACK WALL

Select:

- 1 x 2400mm Base Plate
- 1 x 2400mm Top Plate
- 3 x 2250mm Studs
- 2 x 1132mm Nogs

- Select one 2400mm base plate (Green), one 2400mm top plate (Red) and three studs (Yellow).
- Lay out the framing on a flat surface as per the diagram with the top plate at the top. Ensure that the notches on the top and bottom plates face outwards as shown. Nail together using two 75mm nails per join. You can use the 1132mm nogs to position the studs in the right position - 1132mm inside measurement (see diagram).
- Position nogs 1132mm up from topside of the bottom plate to underside of the nog and nail in place with 2 nails in each end.

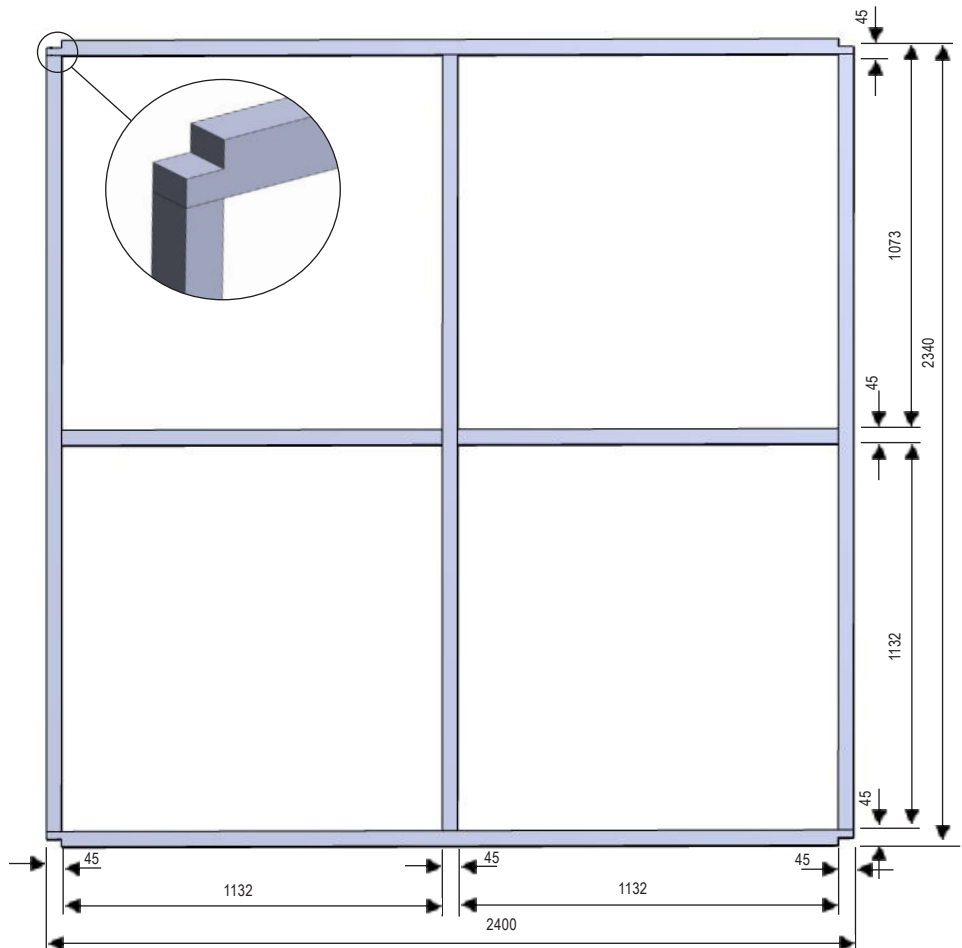

TIMBER FRAME - FRONT WALL

- Select
- 1 x 2400mm Base Plate
 - 1 x 2400mm Top Plate
 - 1 x 1890mm Lintel
 - 4 x 2250mm Studs
 - 2 x 1962mm Studs
 - 4 x 243mm Jack Studs (short studs)
 - 2 x 165mm Nogs

- Lay out the top and bottom plates and the two outside studs, ensuring that the notches face outwards as shown. Nail together at the corners using two 75mm nails per corner.

- Next take the remaining 2 studs (these are door studs). Use the 165mm nogs as spacers to position them 165mm in from the corner studs and nail them in place using 2 x 75mm nails top and bottom.

- Now, position the 2 x 1962mm Lintel Support Studs to the inside of the door studs and down against the base plate. Secure with 2 x nails at each end and 2 x nails skewed into the door stud.

- Nail the lintel on the top of the Lintel Support Studs.

- Select 2 x 243mm Jack Studs. these will be fitted against the door studs above the lintel. Fix at either end with 2 x 75mm nails.

- Using the other 2 x 243mm Jack studs, position them 570mm in from either side and nail them in place with 2 x 75mm nails at either end.

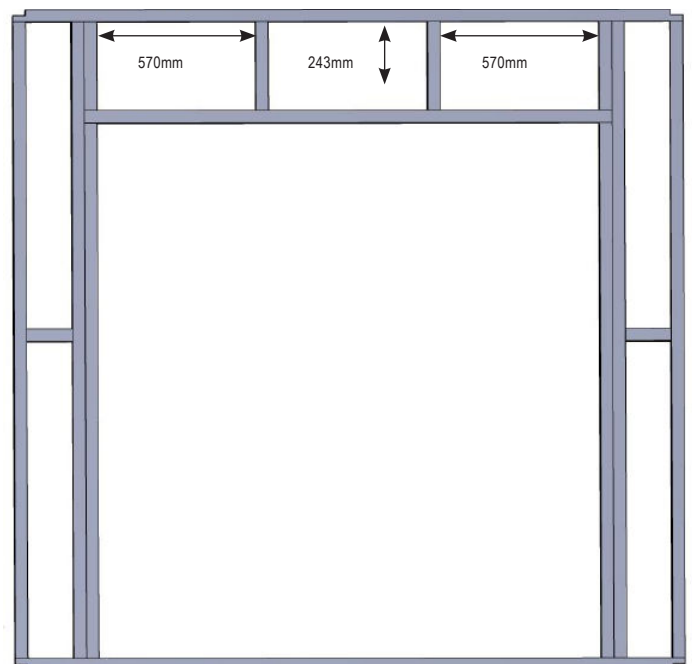
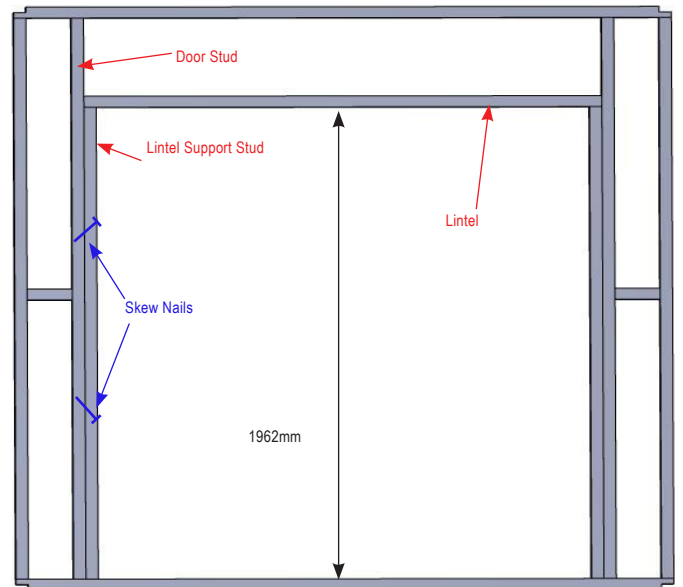
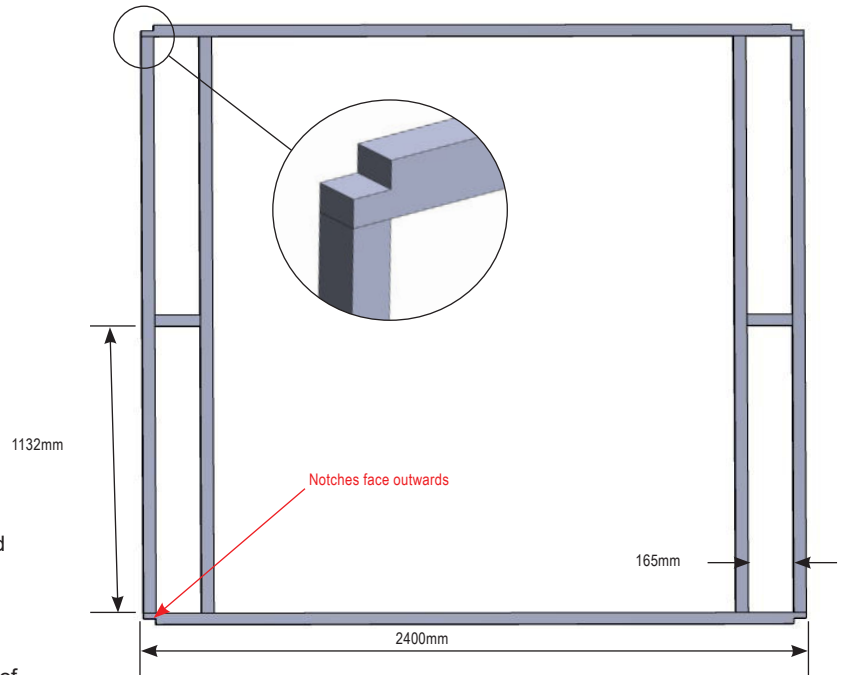

ASSEMBLING THE TIMBER FRAME

- Select 2 x 2000mm base plates (Green) and 2 x 2000mm top plates (Red). With the front wall lying on the ground, fit the notched out ends into the corresponding check outs in the front wall framing.
- Ensure Green joins to Green and Red joins to Red and nail with 2 x 75mm nails.

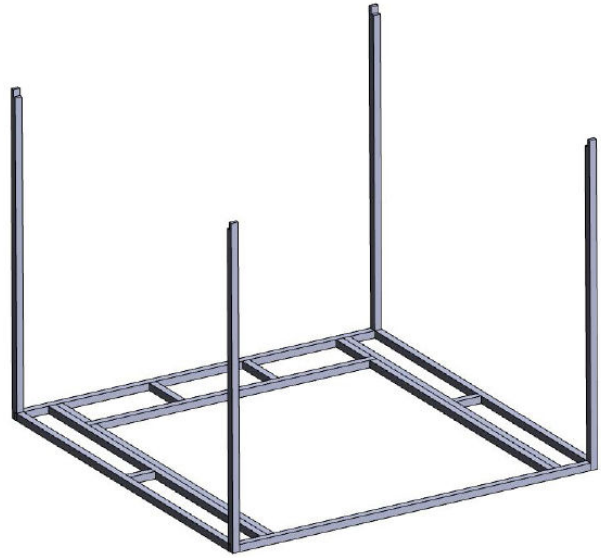

- Position the completed back wall frame on top of the 4 upright framing plates.
- While someone supports the frame to ensure that it doesn't move around, nail this back frame in place with 2 x 75mm nails at each corner.

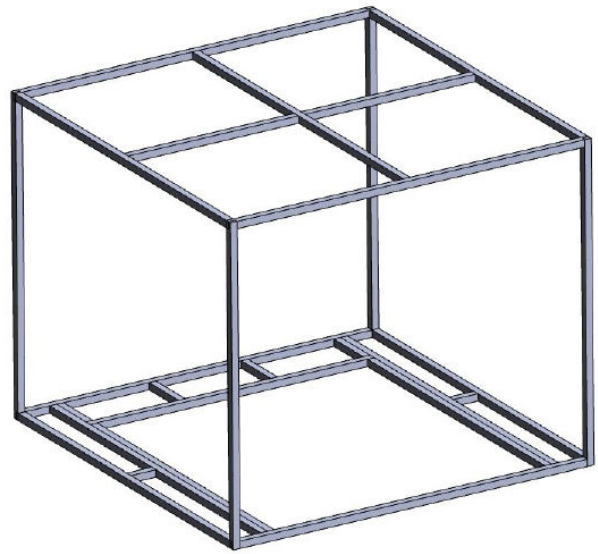

Carefully roll the frame over onto its base. (Pieces of timber from the packaging may be used to temporarily brace the frame before rolling it over).

- Take the 2 remaining end wall nogs and fit these into the end walls at the same height as the other nogs. Nail in place at either end.

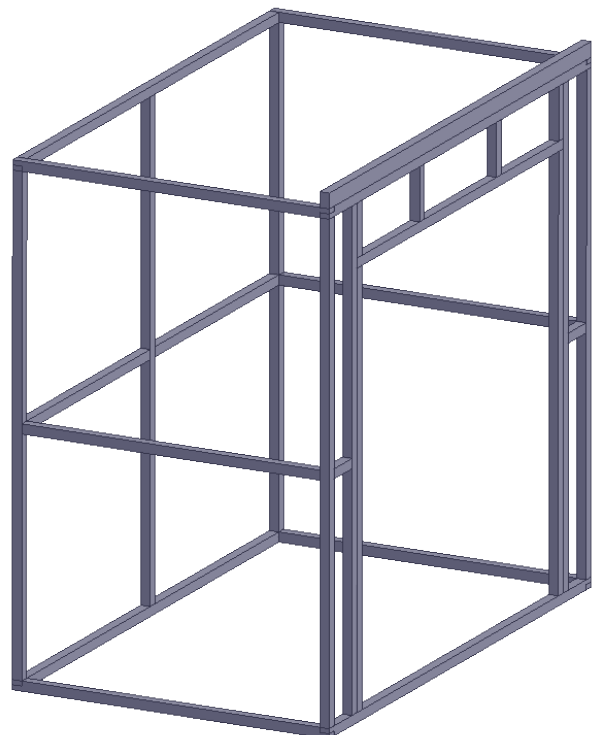

ASSEMBLING THE TIMBER FRAME

- Position the Top Plate Packer on the top of the framing, flush with the front. This provides a 70mm slope for the roof.
- Skew nail to the top plate using 8 x 75mm nails - 2 at each end and the rest evenly spaced.

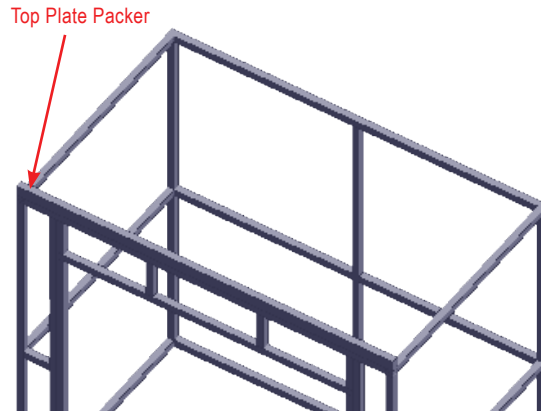

FLOORING - CONCRETE SLAB

If your shed has a concrete slab floor, position the frame onto the base. Note: if the shed floor is against a house or fence, you can position the shed after it has been built (but before you install the roller door).

Please note that the design of the shed means that the wall cladding protrudes below the bottom of timber base plate. So that you are able to build the shed properly you will need to temporarily screw some timber blocks under the base plate to lift it up so that the wall cladding clears the ground while you build the shed. These will be removed when the shed is ready to position.

- Ensure that the bottom wall frames are running straight and that the studs either side of the door are in the right place.
- Measure diagonally from one inside corner to the other, note the measurement and then measure the opposite diagonal distance. These measurements must be the same for the shed to be square. Adjust if necessary. The frame will overhang the floor to allow the cladding to overlap. Ensure that this measurement is the same right around the shed.
- Screw the timber bottom base plate to the concrete floor using 11 x 100mm dyna bolts through the frame as shown.
- Using a hand saw, Cut through the bottom plate flush with each door stud and discard the centre piece of the frame that lay across the doorway.

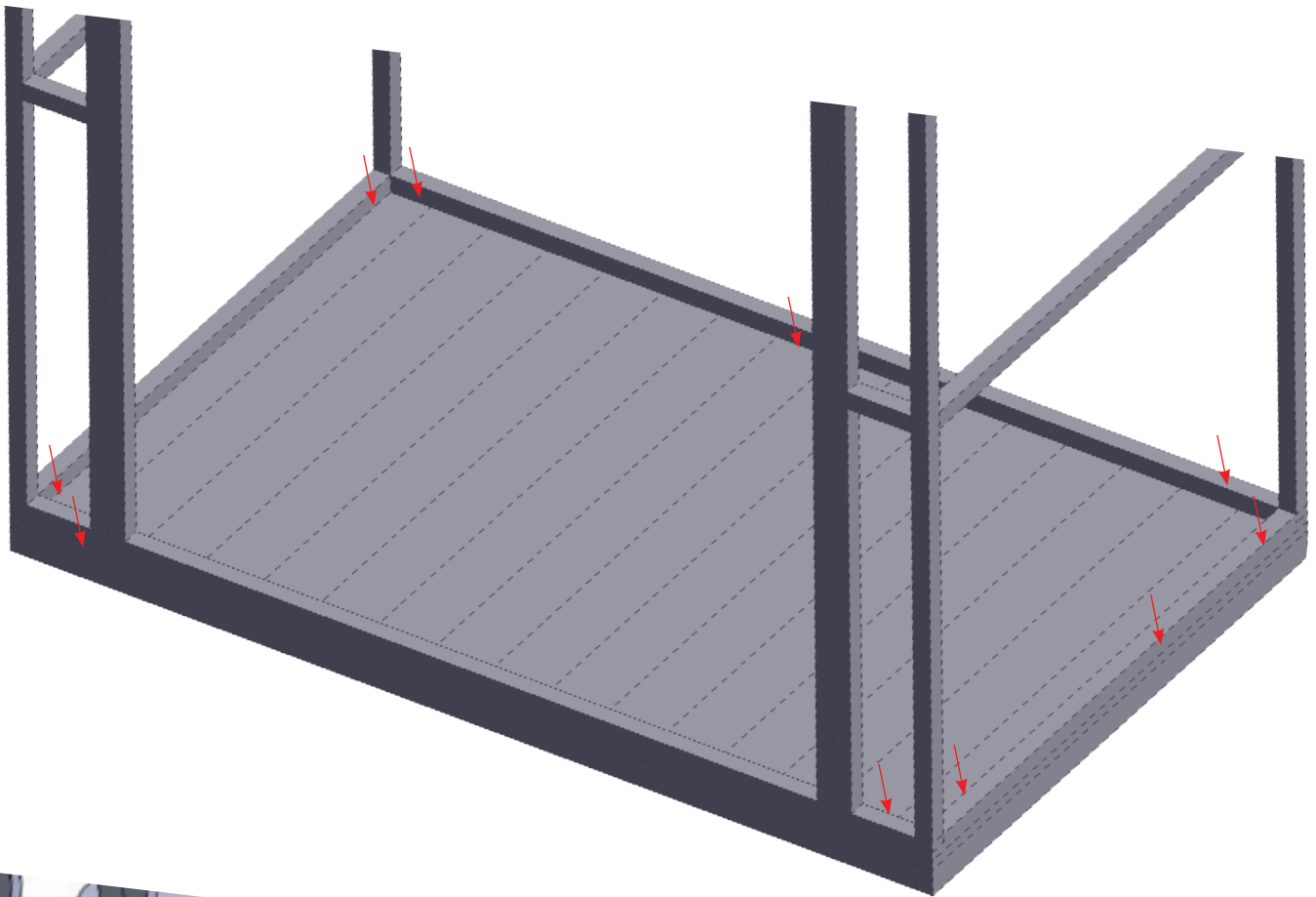

FLOORING - TIMBER FLOOR KIT

If your shed has an **OPTIONAL TIMBER FLOOR KIT**, fit this now.

- Take all 4 x 2400mm Floor Joists and place them parallel (with 45mm face to the ground) as per the diagram. The outside joists are 1500mm apart and the centre 2 joists are 500mm spaces (to the centres).
- Select 2 x 1500mm floorboards and lay them on the top of the joists, one at each end as per the diagram. Nail the floorboards to the joists, flush at the corners, with 2 x 50mm flooring nails at each end.
- When completed, Measure **diagonally** from one outside corner to the other, note the measurement and then measure the opposite diagonal distance. These measurements must be the same for the shed to be square. Adjust if necessary.

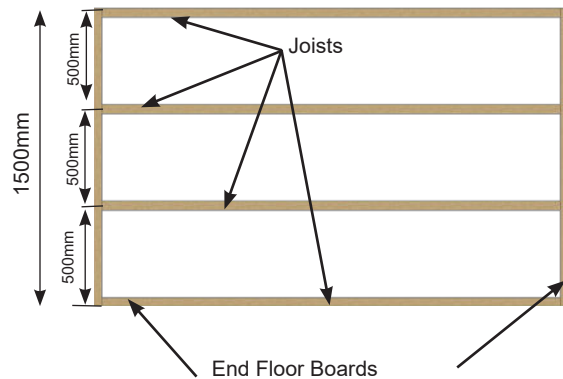

- Once the shed is square, check that the spacings of the remaining 2 x joists are 500mm apart to the centres and nail 2 x 50mm flooring nails through the end floorboards into each joist at each end.
- Check for square again and nail another floor board at each end with 2 x nails into each joist.

FITTING THE REMAINING FLOORBOARDS

- Next lay all of the floorboards onto the joists. One will need to be cut down lengthwise to fill the final gap (fig. 1).
- Starting from one end, lay the floorboards in place until you reach the middle of the floor. Then start fitting them from the other end until you have a gap near the middle of the floor that the last floor board won't fit into.
- When all of the floorboards are in place, measure the width of the remaining gap and add 3-4mm to ensure a tight fit. Cut the board lengthwise to this measurement (fig. 1).
- Remove 2 full floorboards and fit the cut down board (fig.2). Make sure that the ends of all the boards are straight and aligned with the joists at both ends.
- Place the final 2 boards in place inverted as per fig.3, and align the ends to the rest for the floor. Stand firmly on the inverted boards to push them into place and tighten all of the floorboards.
- Finally, nail all of the floor boards to the joists with 2 x nails per board into each joist.

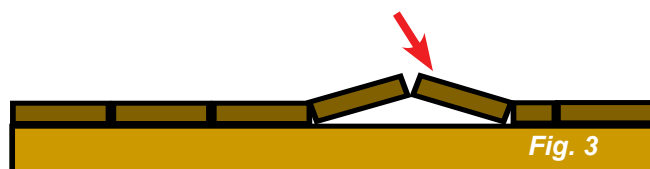
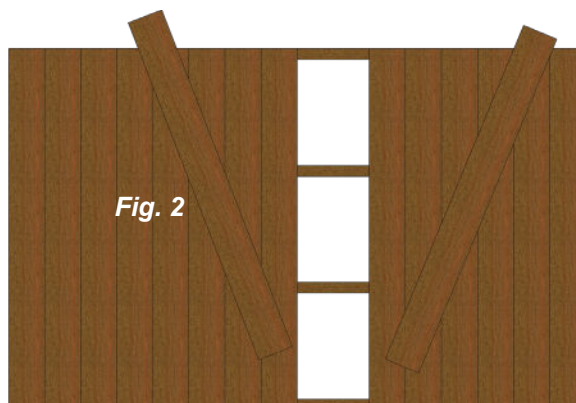
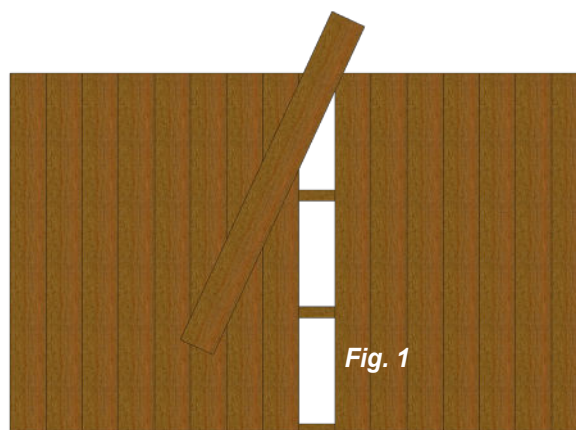

Your floor is now complete and ready for your shed!

FLOORING - PLYWOOD FLOOR KIT

If your shed has an **OPTIONAL PLYWOOD FLOOR KIT**, fit this now.

- Take the 4 x 2310mm long floor joists and lay them out parallel to each other on their short edges as shown (45mm face to the ground). Lay the 2 x 1500mm Joists across the ends.
- Using 8 x 75mm screws, screw the outside joists together at the corners using 2 screws per corner.
- Take 1 x 440mm Joist, and using it as a measuring packer, position the next internal joist at one end and fasten with 2 screws. Repeat at the other end.
- Position and attached the other remaining 2 x joists the same way.
- Measure in 1200mm from the LH end and mark the centre position on all joists. Take 1 x 440mm joist and align it with the centre mark. Screw in from the outside using 2 x 75mm screws. Do the same with the other end. The other 2 x 440mm joists should be positioned and screwed into place as per the above diagram
- When completed, measure **diagonally** from one outside corner to the other, note the measurement and then measure the opposite diagonal distance. These measurements must be the same for the shed to be square. Adjust if necessary
- Place one sheet of plywood in position running the depth of the 1500mm side as per the diagram.
- Align the sheet with the edges of the floor frame, take 22 x 40mm screws and fasten the plywood to the joists and base plates as shown (red dots). As the ply only overlaps half of the centre joist, angle the screws inwards to ensure that they don't miss the joist. Repeat with the other sheet.
- Lift the shed frame onto the floor and align the frame with all edges of the floor. Once again check that the shed is square using the method described above.
- Screw the shed frame to the floor using 11 x 75mm screws through the base plate as per the red dots in the diagram.

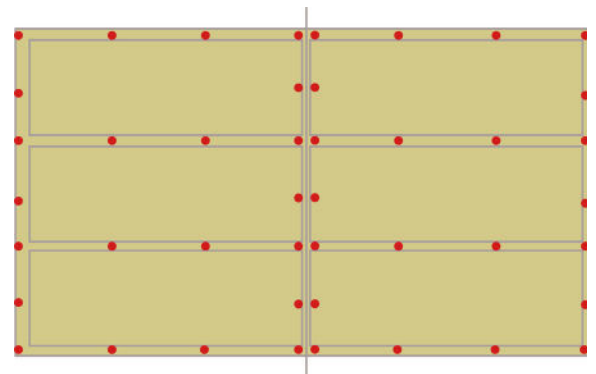
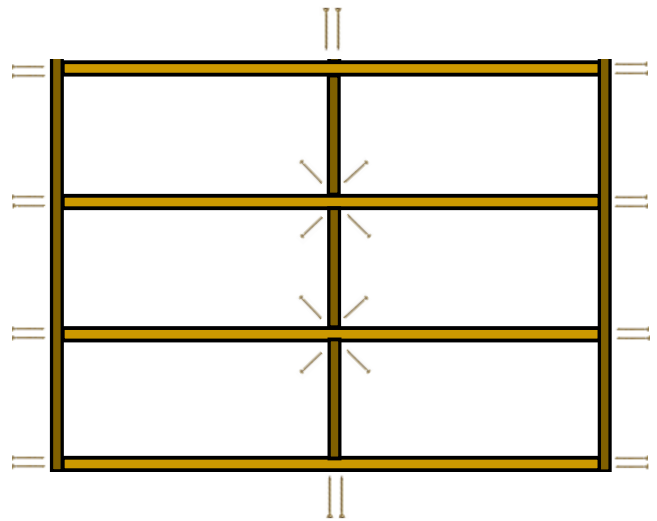

Now we need to remove the base plate in the doorway at the front.

- With a handsaw, cut through the base plate flush with the door studs on either side and discard the centre piece.
- Attach door step flashing using 3 x 40mm screws, screwing through the top of the top of the flashing.

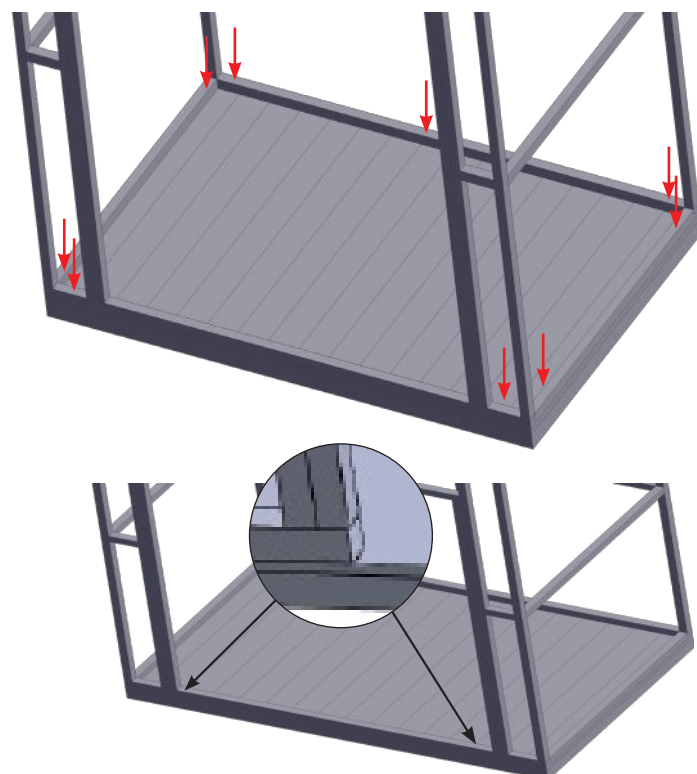

ATTACHING DPC TO FRAME

Waterproofing is important to prevent leaks and keep the timber framing dry. Your shed has been supplied with a roll of DPC tape (Damp Proof Course)

If your shed is positioned on a concrete or raised timber floor it is important that you should install the DPC before attaching the cladding to prevent water flowing between the base plate and floor.

AROUND THE BASE

- Starting at one corner, run a length of DPC tape across the front of the shed from one corner to the other. Holding the top of the tape flush with the top of the base plate (overlapping the concrete floor) nail it to the base plate using 30mm clouts about 600mm apart. See the blue highlights in the diagrams below.
- Wrap the tape around the corner and nail it in the same position to the other 3 sides of the shed.

CORNERS AND DOOR STUDS

- On the front corner, start the DPC flush with the top of the top timber plate. Fold it around the corner of the stud and tack it on both faces of the stud a 30mm clout on each side. See red highlights on the diagrams.
- Run the tape down the stud to the bottom of the base plate and cut. Nail to that bottom the same as the top and put 3 more 300mm clouts evenly spaced up the front and side faces of the stud. Repeat with the other 3 corners.
- Repeat with 2 x door studs from the bottom of the base plate up under the door lintel. Nail as per the corners.

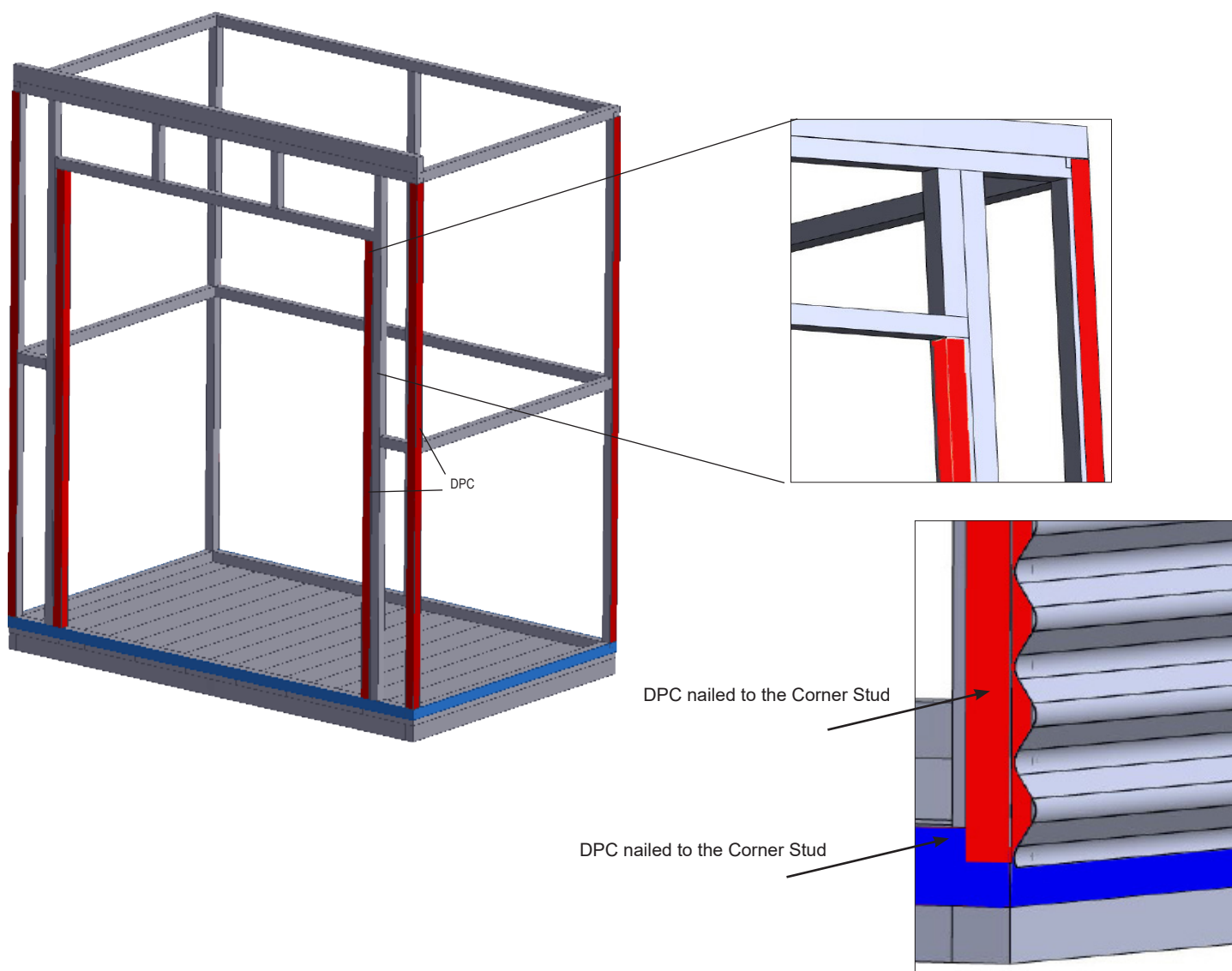

ATTACHING THE DOOR HEAD FLASHING

The door head flashing sits up underneath the lintel to cover the timber framing that would otherwise be exposed to the weather.

- Select the door head flashing and position flashing on underneath and outside face of lintel. It should fit snugly between the door studs.
- Holding the flashing in tight, nail it to the lintel using 6 x 30mm clouts, 3 x on the underside of the lintel and 3 on the front face of the flashing.

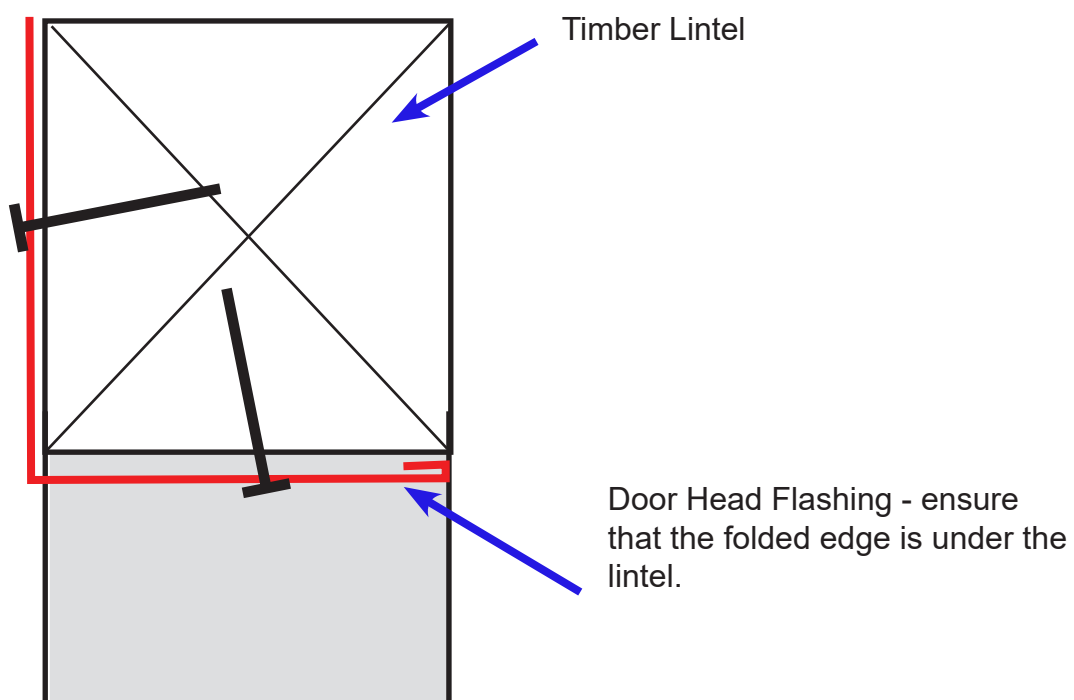
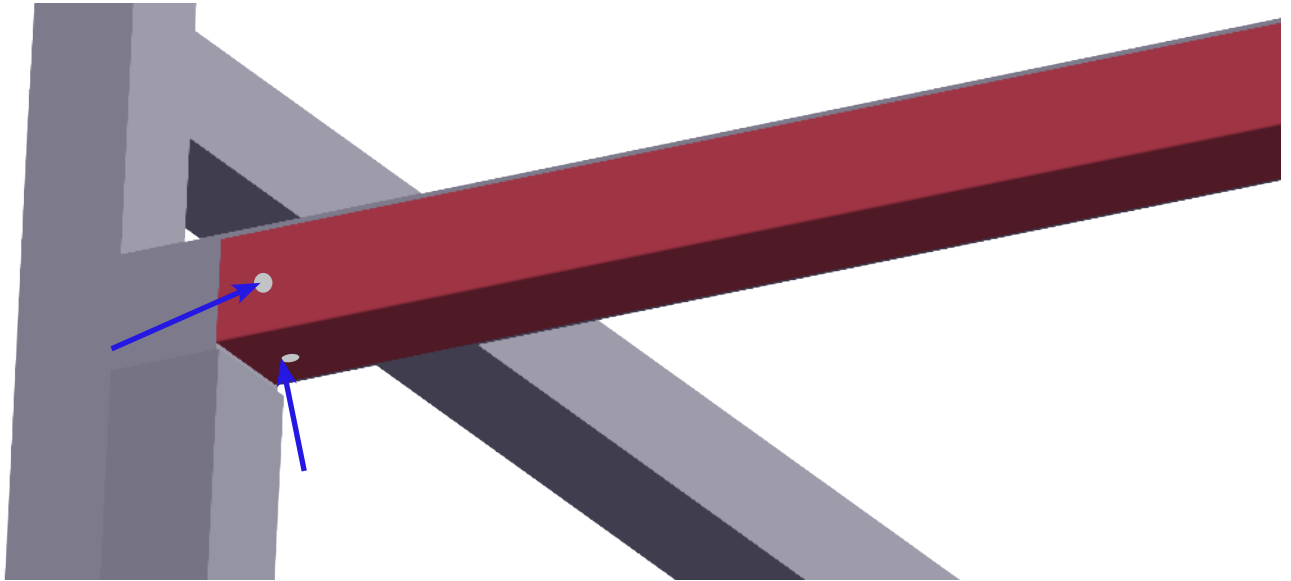

WALL CLADDING

TO AVOID CORROSION:

- Where at all possible try not to trap metal filings between two sheets. Remove all metal filings before riveting.
- Carbon in pencils reacts with the Zinc/Aluminium coating on steel. Use an ink pen to mark the steel as required.

WALL CLADDING FIXING PATTERN

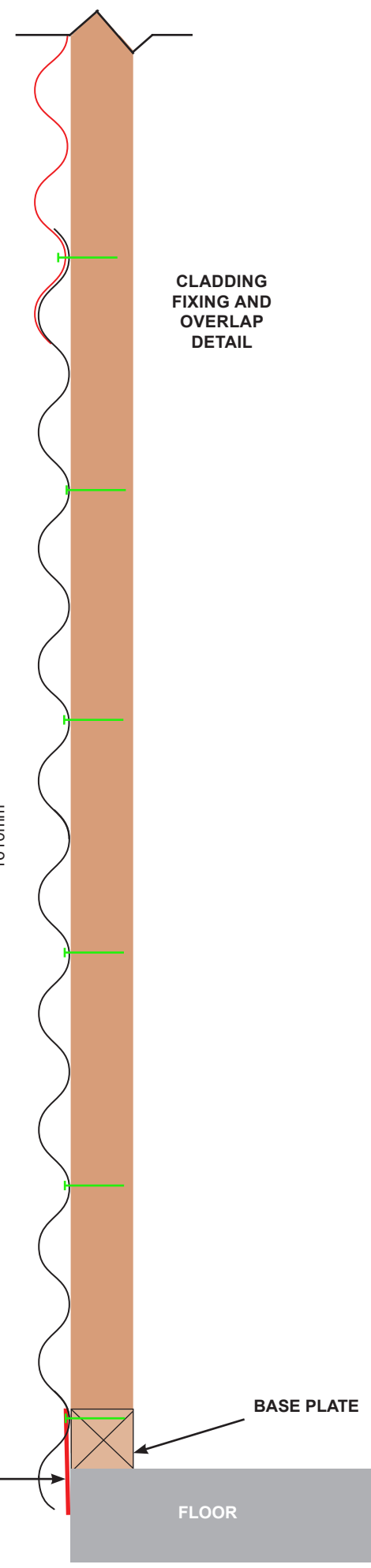
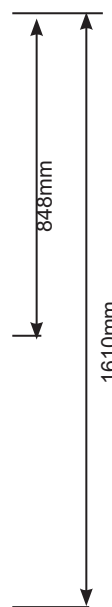
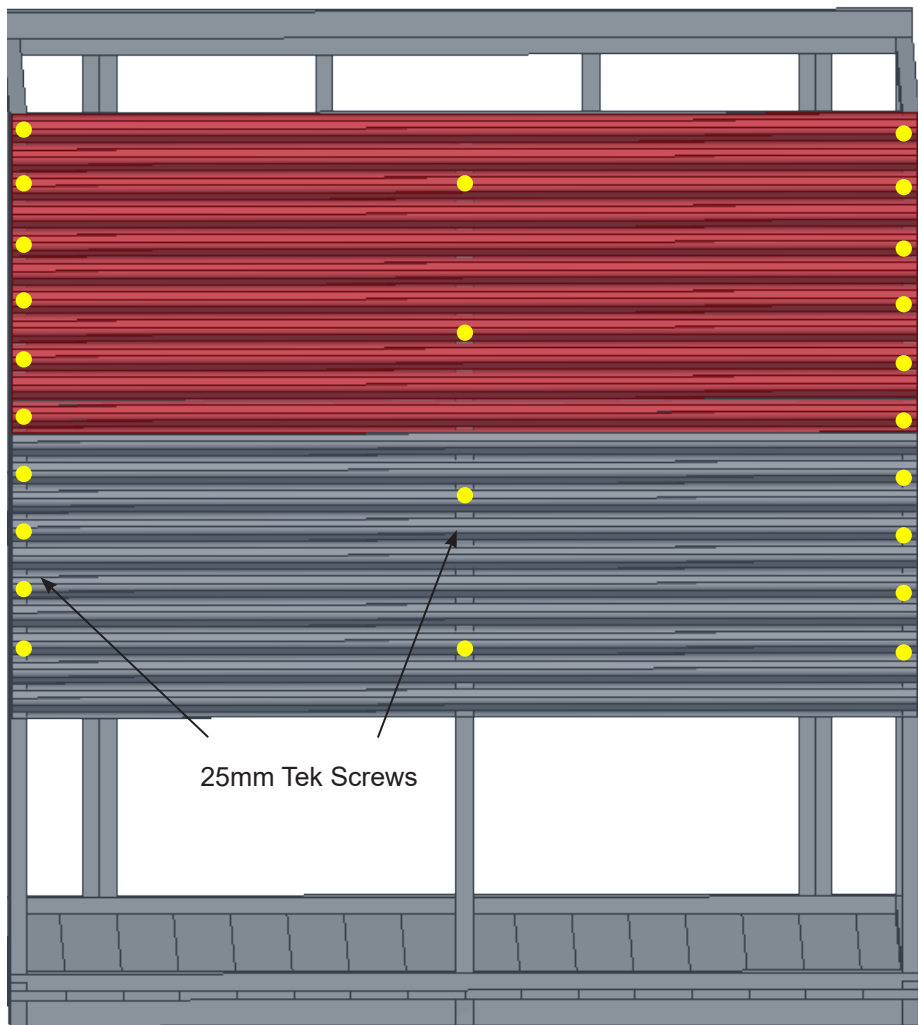

WALL CLADDING - BACK & ENDS

Note - When attaching wall cladding, always ensure that the top sheet is flush with the top of the top timber framing plate and that the ends of the cladding sheets are **flush and parallel** with studs. This will ensure that wall panels are square. Always screw wall sheets through the trough (inner rib closest to the frame) of the profile.

TOP WALL SHEET

- Take a 2400mm length rear wall sheet and hold it in position at the top of the back wall. It must be flush with the top of top timber plate and both ends must be flush with the outside of the studs at either end. (Fig. 1)
- Using 1 x 25mm tek screw, attach one end of the sheet to the frame at the top left hand corner of the sheet (Fig.1)(a). Place the screw approx 25mm in from end of the sheet (the corner flashing will cover the screws).
- Repeat at the top of the sheet at the other end making sure that the cladding is flush with the top of the top plate. (Fig. 1) (b)

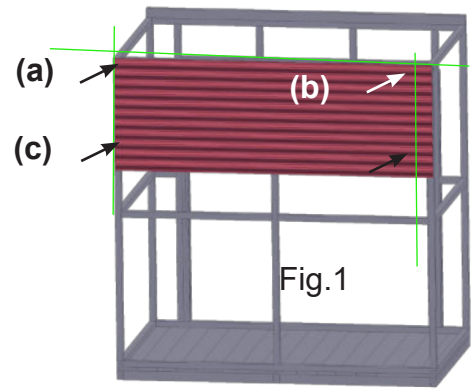

NOTE: The middle sheet will need to lap UNDER the top sheet, so don't screw right at the bottom of the sheet yet! The top sheet will finish 850mm below the top of the framing and the second sheet finisheds 1617mm down (see Wall Cladding Fixing Pattern on the previous page.

- To fix the bottom of the sheet, make a mark on each corner stud 848mm down from the top of the framing. (this is where the sheet will end). Align the edge of the cladding and the corner stud. This ensures the back wall of the shed is square. Make sure that the bottom of the cladding is on the 848mm mark and place 1 x 25mm tek screw 2 ribs up from the bottom of the sheet (Fig. 3)(d). This will let the next sheet slide underneath.

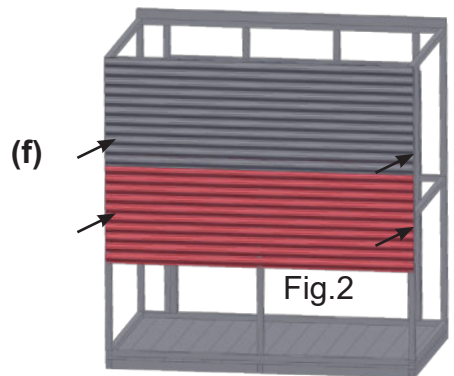

MIDDLE & LOWER WALL SHEETS

- Position the 2nd sheet underneath the first sheet so that it is overlapped correctly (Fig. 3). As per the first sheet, start in the top left hand corner, place a screw in the overlap of the 2 sheets (Fig. 3) (e) and (Fig. 2)(f).
- Repeat at the top at the other end. Once again square the framing up with the cladding and screw the bottom of the sheet using the same process as the top sheet (Fig. 2). Repeat with the bottom wall sheet (Fig.4) Bottom wall sheet should finish approx 30mm below bottom of base plate.
- Using 25mm tek screws in the middle of the sheet, screw the three wall sheets off as per the plan on the previous page

- 5 x 25mm Tek screws per end of each sheet
- 3 x 25mm Tek Screws in each stud of the top wall sheet
- 2 x 25mm Tek Screws in each stud of the middle sheet
- 3 x 25mm Tek Screws in each stud of the bottom sheet.

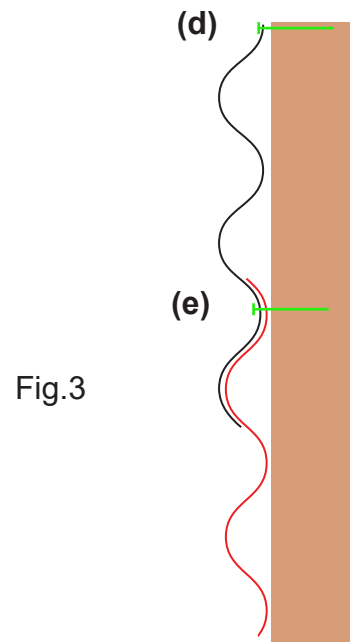

Repeat the above steps with each side wall until you have finished the back and two end walls. **--IMPORTANT -- Make sure you align the side wall corrugate sheets with the back wall sheets so that the height of the ribs line up.**

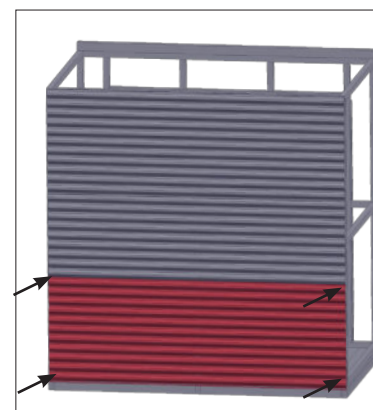

Fig.4

FIXING WALL CLADDING - FRONT

The front wall cladding is attached the same way as the other side walls, except that the bottom cladding sheets either side of the roller door will overlap a lot more than the side and back walls. This will be explained in the step below "BOTTOM SHEET".

OVERDOOR CLADDING SHEET

Fitting the top cladding sheet on the front wall will be a lot easier with 2 people and 2 ladders...

- Select the 2400mm top front wall sheet (this is not a full width sheet). Position the sheet making sure it is flush with the top of the front timber framing and flush with the corner studs at both ends. Fix with 1 x 25mm tek screw at each end. Fit the remaining screws once all of the front wall cladding has been attached.

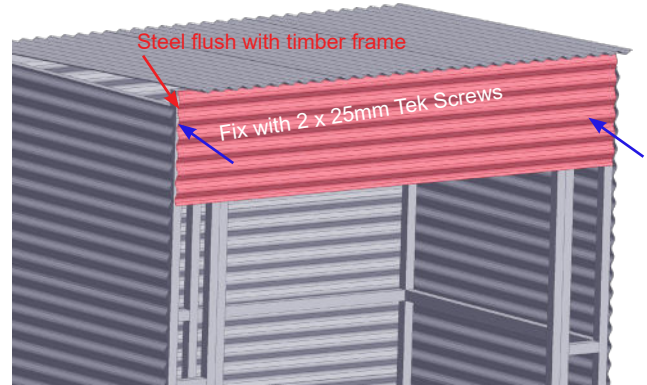

DOOR SIDE CLADDING - TOP SHEET

- Fit the wall sheets each side of doorway using the same process as before. Select a 300mm cladding sheet and lap it underneath the overdoor sheet as per normal overlapping standards. Fix with 2 x 25mm Tek Screws through the overlap.
- Place 2 x more 25mm Tek screws 2 ribs up from the bottom of the sheet either side so the next sheet down can lap underneath.

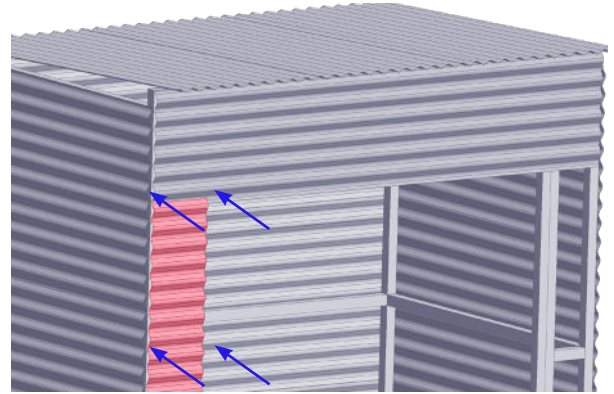

DOOR SIDE CLADDING - MIDDLE SHEET

- Using another 300mm door side cladding sheet, lap it underneath the sheet above as per normal and place 2 x 25mm Tek screws into the overlap as normal.
NOTE: do not place any screws in the bottom of this sheet at this stage!

DOOR SIDE CLADDING - BOTTOM SHEET

NOTE: Because of the Overdoor Cladding Sheet at the top of the front wall, the bottom sheet will lap up under the middle sheet by about 5 ribs. Providing that the sheets have been positioned correctly, the steel profile will match the side walls.

- Take another 300mm front wall cladding sheet and slide it up under the middle sheet until the bottom of the sheet is approx 30mm below the bottom of the shed framing (the same as the side wall).
- Press the sheets against the framing so that the steel overlaps nice and tight. Align the ends of the steel with the corner stud and door stud. Now place 2 x 25mm Tek screws into the bottom of the middle sheet. This will hold both overlapped sheets in place.
- Finally screw off all the sheets with 25mm Tek screws as previous (as per previous fixing details).

REPEAT WITH THE CLADDING ON THE OTHER SIDE OF THE DOOR.

- Finally finish fixing the Overdoor Cladding Sheet - using 25mm tek screws at each end and into the centre of each of the jack studs above door.

ATTACHING THE FLASHINGS

Now it is time to finish the corners by fitting the Corner Flashings. PLEASE NOTE: Do NOT screw tek screws too tightly into the corner and door side flashings as they will pull in and leave a dent.

We will screw the corner flashings onto each corner using 6 x 55mm tek screws per corner, 3 x into each face of the flashing, 2 x at the top, 2 x at the bottom and 2 x in the middle. The top screws should be approx 250mm down from top of top plate.

- Starting with the front RH flashing, hold it in place flush with the top of the **front wall** timber frame. Pre-drill a 3.5mm hole 250mm down, in the front face. Ensure that the flashing is square and parallel with the wall and fasten with a Tek screw. Repeat the process at the bottom of the flashing, taking care to keep the flashing vertically plumb.
- Back at the top, adjust the flashing so that it is perpendicular (vertically level) from the side, pre-drill the hole at the top parallel with the first screw and attach. Repeat at the bottom. Now find the centre of the flashing vertically, pre-drill and fix the 2 middle screws.
- Repeat with all corners

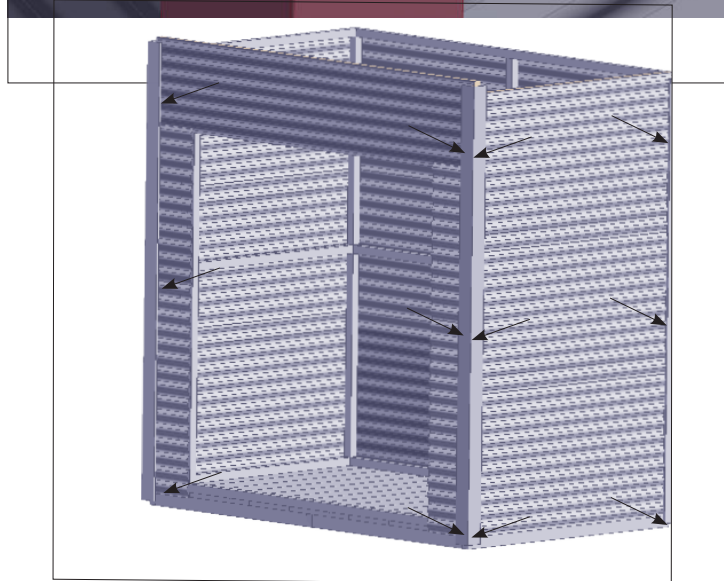
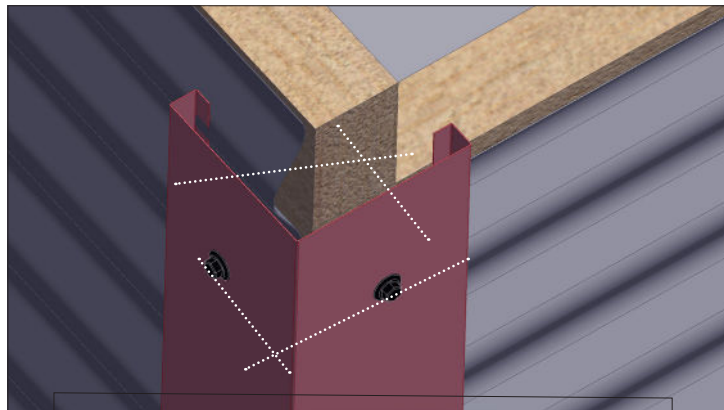

DOOR JAMB FLASHINGS

- Position the door jamb flashing so top is level with underside of lintel.
- Using tin snips, notch bottom of flashing around concrete, ply or timber floor.
- Attach using three 30mm clouts, nailed to inside of stud (top, bottom and middle) and three 55mm tek screws on the outer face screwed through the front wall cladding into the stud.
- Repeat with the Left Door Jamb flashing

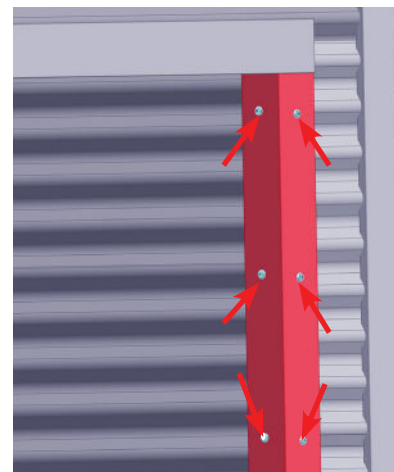

OVER DOOR FLASHING

- Position the door top flashing onto the top of the door jambs and centred on the door. (Note flashing length will protrude approx 5-10mm past outside edge of each door jamb flashing to allow any water runoff to be away from the door).
- Using three 55mm tek screws, (one each end and one in middle) screw the flashing through the front 90mm wide face into the timber lintel.

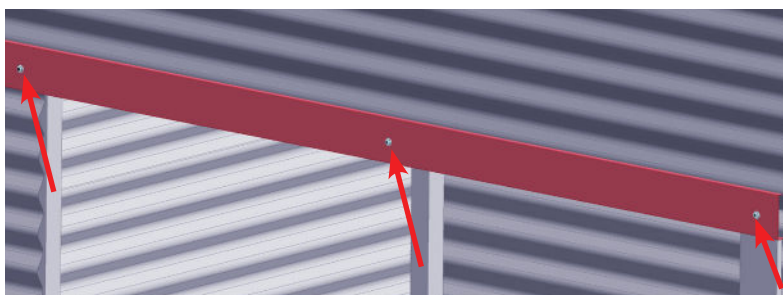

FITTING THE SPOUTING

This shed comes with a built in spouting and downpipe system so that you can easily manage the water runoff.

CUTTING THE DROPPER HOLE

- Preparation for fitting the end caps, you will need to cut out the hole for the downpipe dropper.
- Determine which end you want the downpipe and mark a line 200mm in from the end of the spouting as per the diagram on the right. You will be cutting a 80mm hole in the centre of the base of the spouting.
- Place a mark in the centre of your 200mm line, and using this as the centre, scribe a mark with a diameter of 80mm.
- Cut out the hole by drilling a few small holes then using tin snips to enlarge to the correct size.

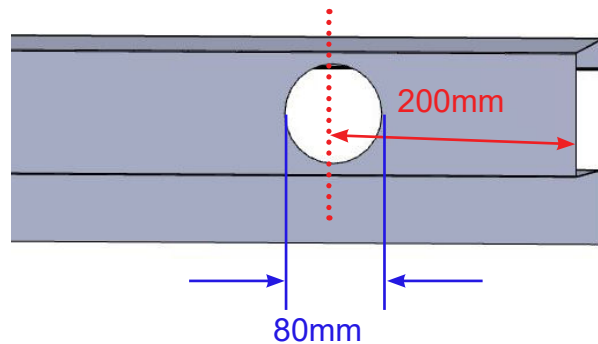

FITTING THE END CAPS

- The end caps need to be inserted into the inside of each end of the spouting and sealed up to stop the water from running out.
- Select the first end cap and dry fit it (no silicone) so that you are prepared and know where it will be sitting in the spouting for when you have wet silicone. Pre-drilling your first rivet hole is helpful for positioning when the silicone is applied.
- Open the RTV silicone and spread a bead around the 3 sides of the end cap that will be in contact with the inside of the spouting. Fit the first end cap to the end of the spouting and rivet in the predrilled hole. Insert all remaining 5 rivets as shown in the diagram.
- Wipe excess silicone off the outside of the spouting immediately and spread any extra around inside the spouting firmly into the join for a watertight seal. Repeat with the other end cap.
- Once the end caps are fitted, position the spouting centrally on the top plate at the back of the shed (it will overhang each side by approx. 20mm) Nail to the top plate using 4 x 30mm clouts, one at each end and two evenly spaced in the middle

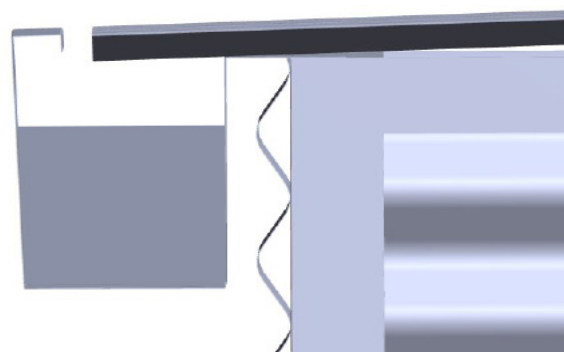
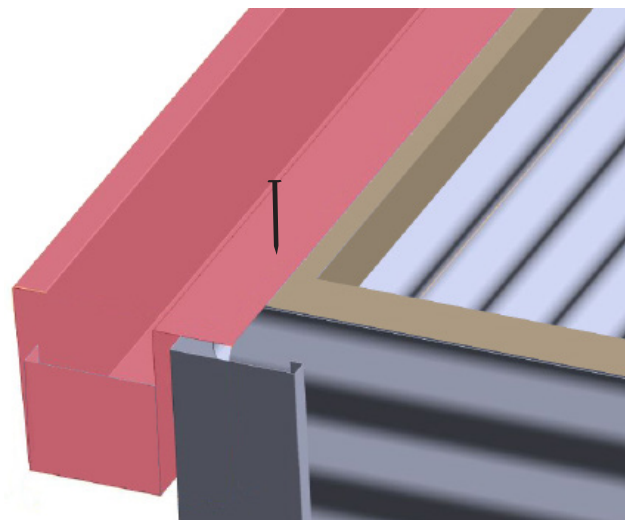
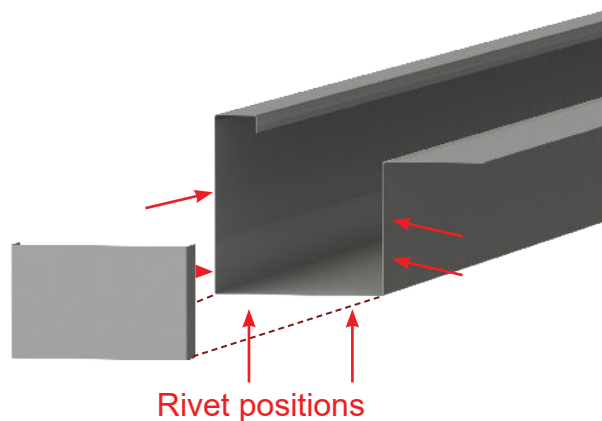

FITTING THE DOWNPIPE

FITTING THE DOWNPIPE

- Silicone the lip of the dropper that will be in contact with the spouting. Place it in the hole. Make sure it is straight. Add extra silicone as required for a watertight seal. Allow the silicone to dry.
- Measure and cut the downpipe to the right length, push it up tight and secure tightly by using one rivet through into the dropper and riveting the two brackets to rear wall cladding.
- Position the downpipe cover flashing over downpipe and rivet to wall cladding using 6 rivets.

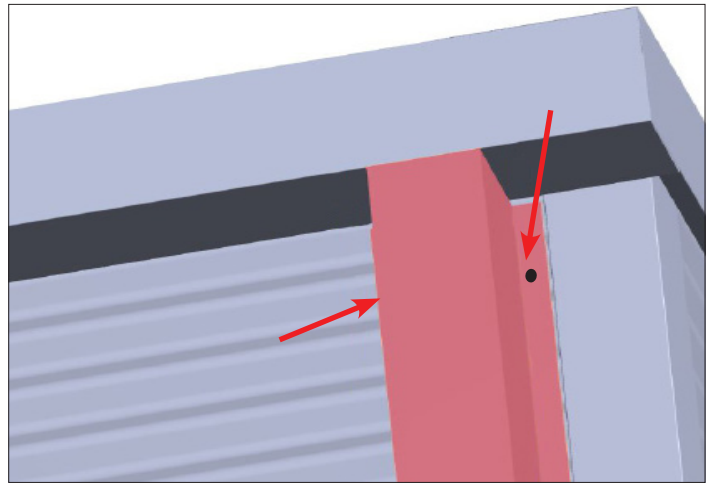
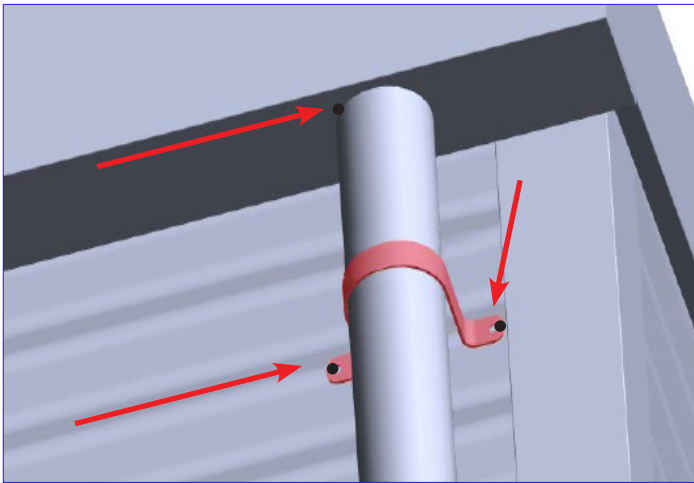
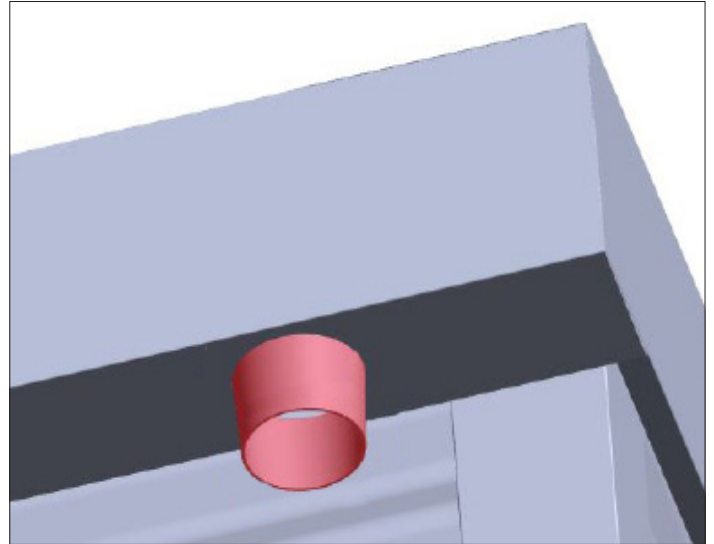
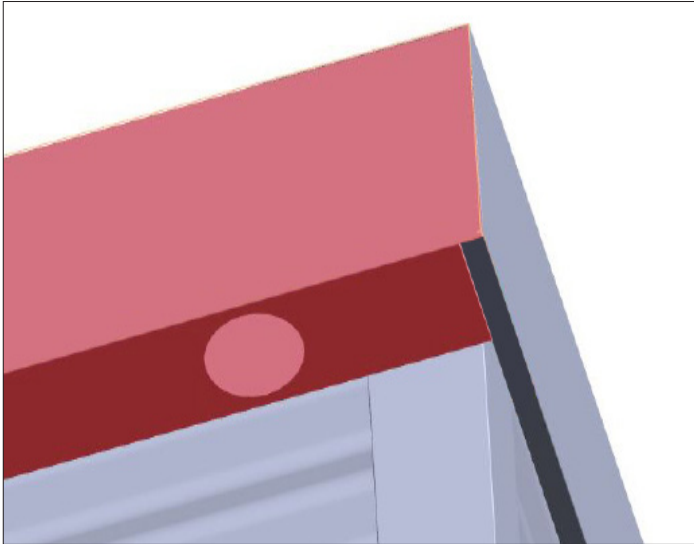

FITTING THE FRONT TOP PLATE FLASHING

- The Front Top Plate Flashing sits on the top plate and comes down the front of the shed over the top of the front wall cladding. The folded edge of the flashing is on the front part of the flashing.
- Place the flashing on the top plate with the folded edge facing down. Ensure that it is flush with the timber at each end and nail in place using 4 x 30mm clouts on the top, down into the top plate.

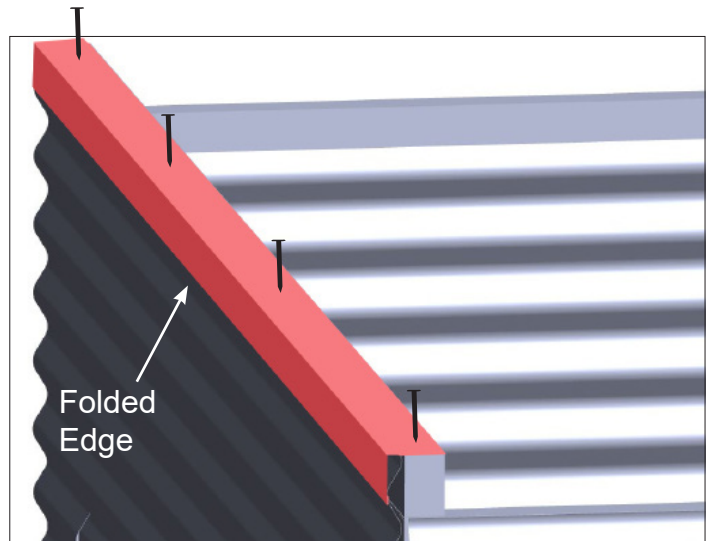

ROOF

If an optional clear roof sheet has been supplied, this can be fitted in any of the middle positions. (Note - both edges of clear roof sheet overlap the steel sheets at each side vs the steel sheets that are under on one edge and over on the other).

- Starting from one end of the shed, place the first roof sheet into position. The edge of the sheet should be 10mm in from outside edge of the timber top plate and overhang the front of the top plate by 250mm. (Or 230mm from top plate flashing)
- Overlap the centre roof sheet with the first one and align the ends. Repeat with the remaining roof sheet(s). Make sure all the ends of the sheets are aligned.
- Reach in from the back of the shed and place 1x rivet in the overlap, 600mm in from the back. Repeat with another rivet 600mm in from the front of the sheet. Repeat with all of the overlap joins.
- Now that the sheets are joined together, adjust them so that they are square on with the shed and that the top plates are straight. At the front of the shed, create an overhang of 250mm past the front of the top plate.

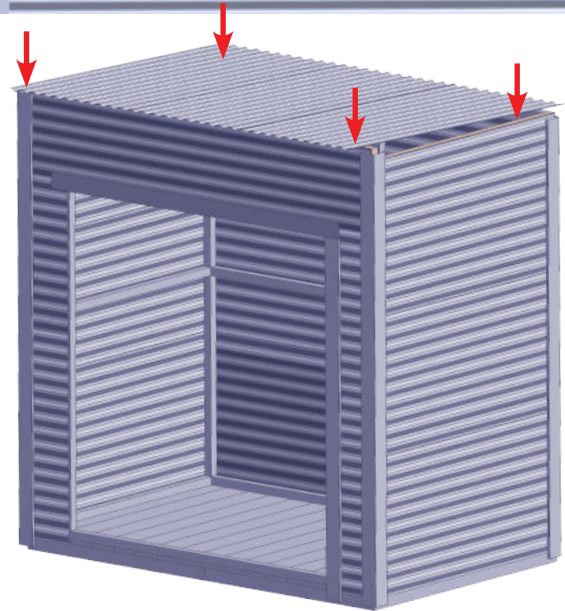
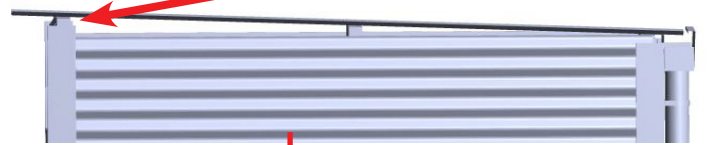
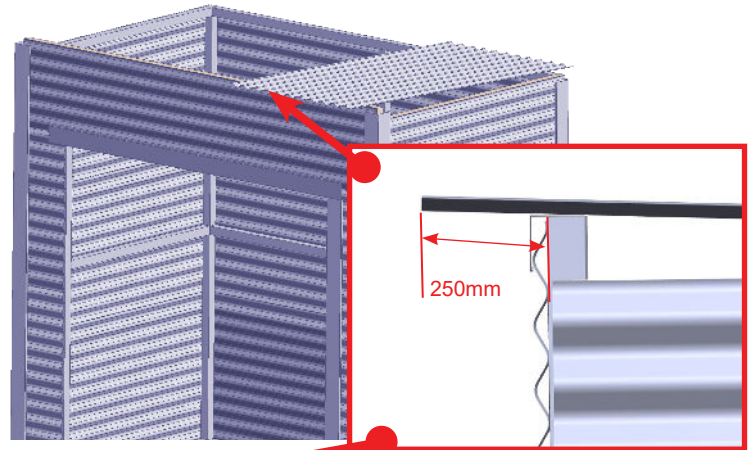

- Starting at one end, make sure the edge of the sheet is 10mm in from the side of the shed and screw 1 x 55mm tek screw through the top of the crest on corrugate profile into the top plate front and rear.
- Repeat at the other end.
- Check that everything is aligned and fit the rest of the screws front and rear using the Roof Fixing Pattern below as a guide. Start with the overlaps in the sheets and then 1 x screw on the 3rd rib either side of each join - see fig.1 below.

ROOF FIXING PATTERN

1. Steel roof cladding - start from one end and overlap each next sheet -
2. Clear Panel - The Clear Panel overlaps the steel sheets on either side (shown in red - not to scale!)

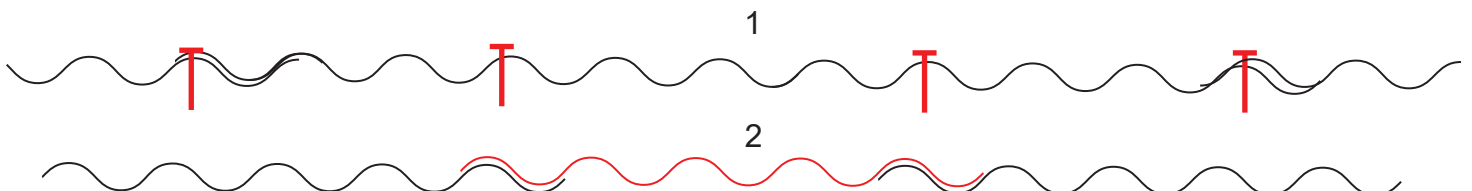
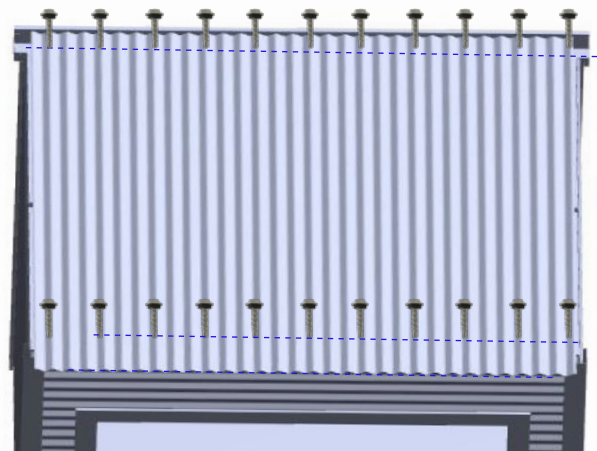

FASCIA, SPOUTING & BARGE

- Select the left hand barge flashing. This will fit in between the fascia and the back spouting. We will be attaching the barges to the spouting at the back first and fitting the fascia last.
- Hold the flashing in firmly against the side of the shed spanning over the roof corrugate and down the side of the shed.
- Line the end of the barge up with the back of the spouting. The barge should fit **over the top and bottom of the spouting**. Drill a 3.5mm hole into the top of the spouting in the corner and fix 2 x rivets.
- Using 3 rivets equally spaced per barge, secure top of barge flashings to roof sheets.
- Repeat the process with the barge on the other side.

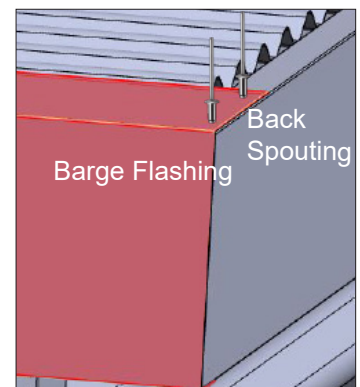
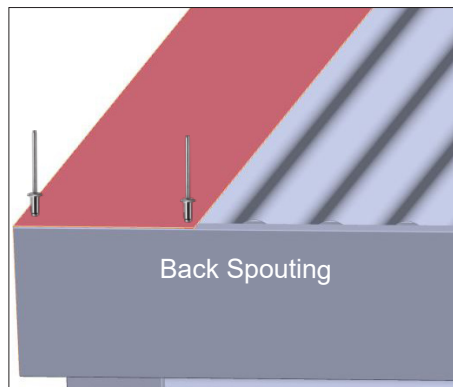
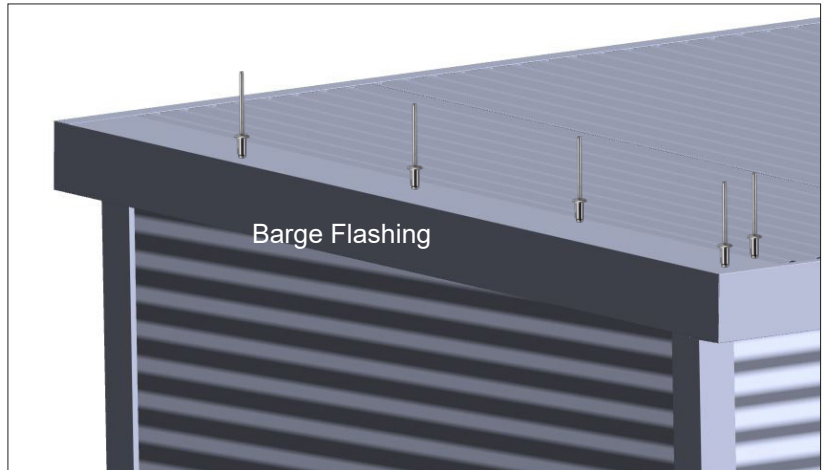

- Install fascia, and screw its ends to barge flashings at both top and bottom using four 25mm Hex head Tek screws.

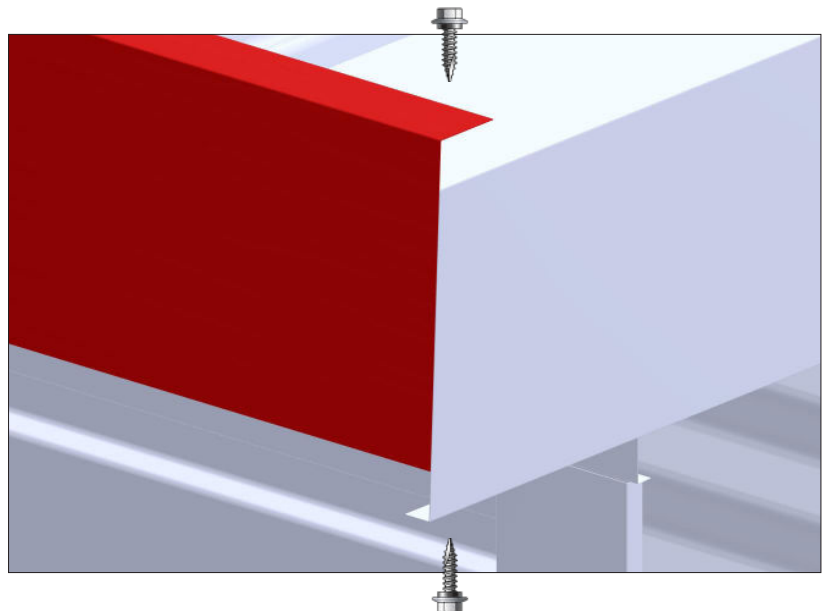

- Fasten top of the fascia to the roof sheeting, one 25mm Hex head Tek screw in the centre of each sheet.

- Fasten the underneath of the fascia to the roof sheets using rivets, equally spaced, 3 rivets per sheet.

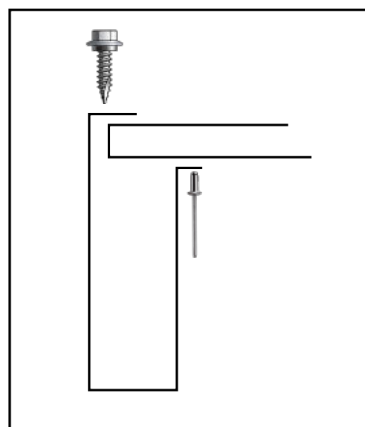

ROLLER DOOR

BEFORE YOU BEGIN

- This Roll-A-Door is designed and tested to provide security, attractive appearance and smooth, low effort operation provided it is installed and operated in strict accordance with the following safety warnings. Failure to comply with the following instructions may result in death, serious personal injury or property damage.
- NOTE:** Do not unwrap packaging around roller door until requested, as this will untension the door.

SERIES 1 ROLL-A-DOOR

DESCRIPTION	ITEM	QTY	PACKED	CHECKED
Rolled plastic wrapped door	A	1	<input type="checkbox"/>	<input type="checkbox"/>
"A" Style brackets, left & right hand side	B	2	<input type="checkbox"/>	<input type="checkbox"/>
Door guides, left & right hand side	C	2	<input type="checkbox"/>	<input type="checkbox"/>
Steel locking bars	D	2	<input type="checkbox"/>	<input type="checkbox"/>
SMALL PARTS BAG CONTAINING:				
Guide clips (door size dependent)	E	4-10	<input type="checkbox"/>	<input type="checkbox"/>
Door handle and fixing to suit	F	1	<input type="checkbox"/>	<input type="checkbox"/>
Bottom rail stops and 6mm screws	G	2	<input type="checkbox"/>	<input type="checkbox"/>
Faceplate and lock assembly (2 keys)	H	1	<input type="checkbox"/>	<input type="checkbox"/>
Locking bar retainer	I	2	<input type="checkbox"/>	<input type="checkbox"/>
Locking bar covers	J	2	<input type="checkbox"/>	<input type="checkbox"/>
"U" Bolts	K	2	<input type="checkbox"/>	<input type="checkbox"/>
Axel / bracket saddles	L	2	<input type="checkbox"/>	<input type="checkbox"/>
8mm nuts for "U" bolts	M	4	<input type="checkbox"/>	<input type="checkbox"/>
Counter sunk screws for lock and fascia	N	2	<input type="checkbox"/>	<input type="checkbox"/>
7mm x 4mm mushroom head screws for locking bar	O	2	<input type="checkbox"/>	<input type="checkbox"/>
4mm x 6mm screws for handle	P	2	<input type="checkbox"/>	<input type="checkbox"/>
10mm washers	Q	4	<input type="checkbox"/>	<input type="checkbox"/>
8mm washers (door size dependent)	R	8-12	<input type="checkbox"/>	<input type="checkbox"/>

TOOLS

- A professional installers tool kit is required to install the door. You will need assistance to help you lift the door up safely and carry out some other steps. A Soft Wood Chock will help hold the door until the guides and stops are fitted. Prepare a 400mm long Wood Chock as per diagram.



Wood chock

ROLLER DOOR

PARTS CHECKLIST

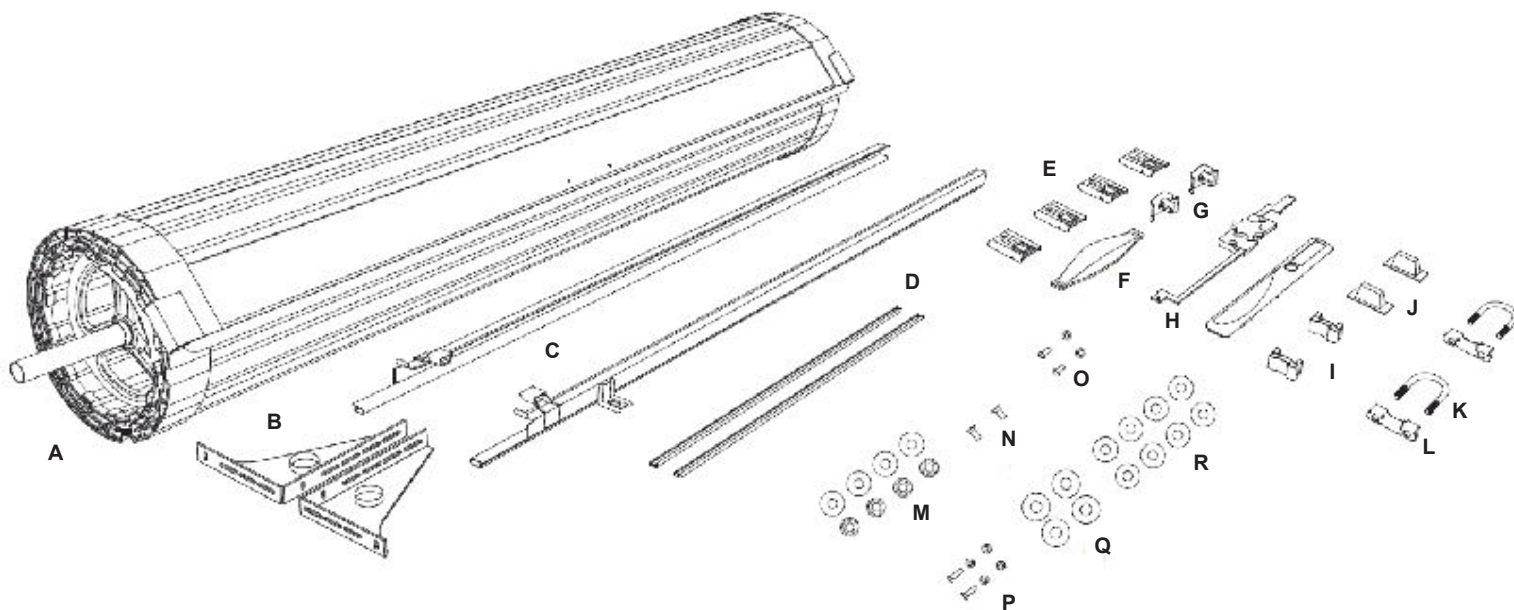

REQUIREMENTS BEFORE INSTALLATION

- **Level and plumb** - The door must be installed in an absolutely level position, if opening is not level and square, appearance and/or sideroom requirements will be affected. The floor should be level or recessed across the opening to avoid gaps.

MEASUREMENTS

- **Opening width** - As the standard door overlaps each side by 30mm or more, the door should be 60mm wider than the 1800mm opening.
- **Opening height** - The door opening height (or drive through clearance) indicates the distance between the ground and rubber seal at the bottom of the door, with door fully open. For doors with a handle, the bottom rail is recommended to hang a minimum of 80mm below the lintel.

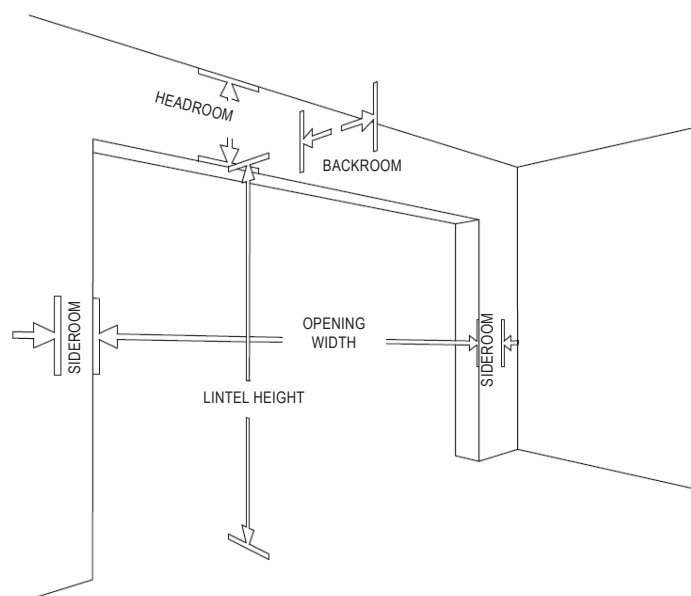

ROLLER DOOR

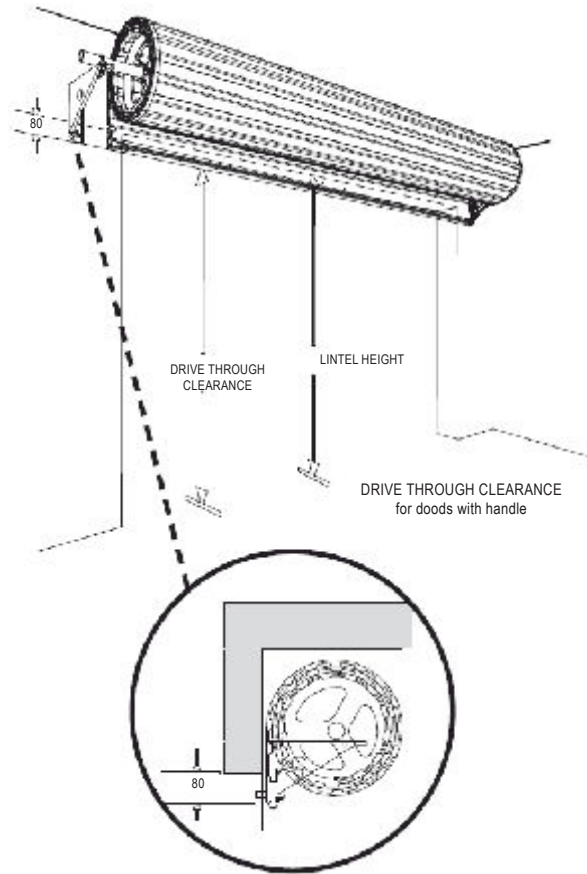

HEADROOM REQUIREMENTS FOR DOORS

- **Headroom** - A minimum of 410mm of headroom is required. If the door is installed lower into the opening than shown below, additional loss of door opening height will result.

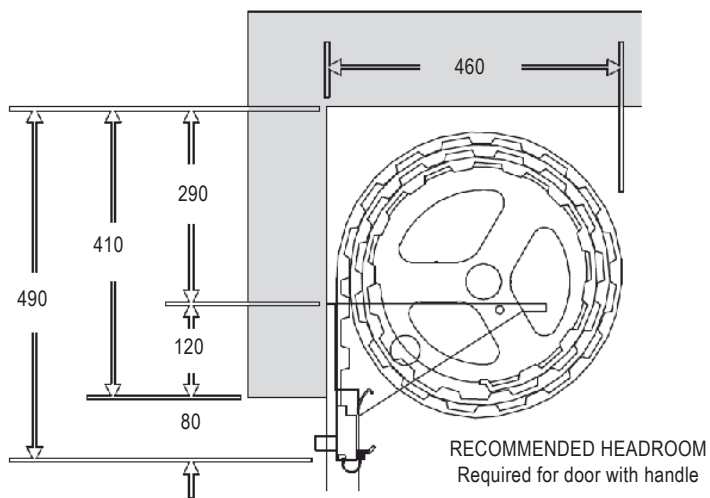

ROLLER DOOR

INSTALL FIRST BRACKET

- Measure the door curtain width and mark where edge of curtain will be, allowing for over lap on each side of the opening.
- Add clearance of 20-30mm from edge of curtain to inside edge of bracket to determine positioning of the bracket.
- Headroom. Measure up 120mm from underside of the lintel.
- Mark two hole positions using top and bottom slots on the bracket.
- Drill both holes, then attach bracket using the 50mm x 10mm coach screws and washers supplied.

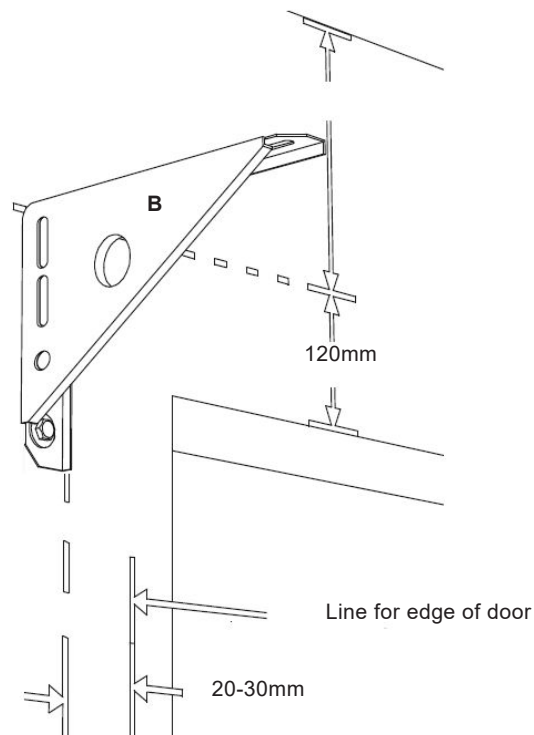

INSTALL SECOND BRACKET

- Using a water level or level /straight edge, mark the position for the second bracket
- Re-check levels then drill and fix as with first bracket.

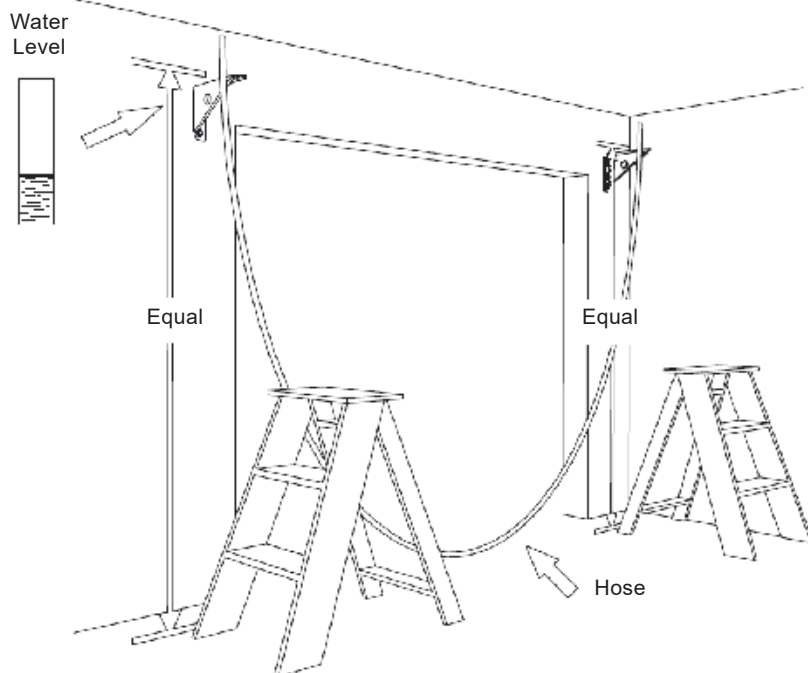

CAUTION: The brackets must be perfectly level for the door to operate.

PLACE DOOR ON BRACKET

- Do not cut plastic or packaging yet.
- Using two persons and correct lifting techniques, lift door onto opening).
- Immediately loosely fit the "U" bolts (K) , saddles (L) , washers and nuts (M) to the brackets in position shown. Fitting the 'U' bolts eliminates the door falling from the brackets. (Do not tighten yet)

ROLLER DOOR

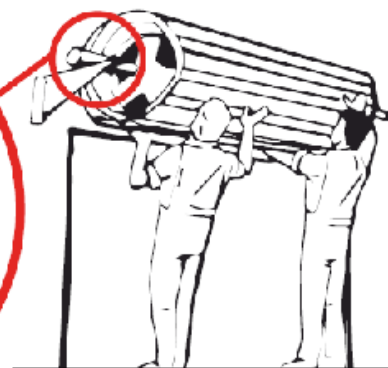
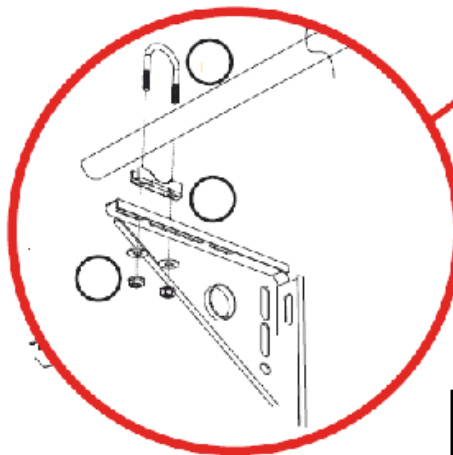
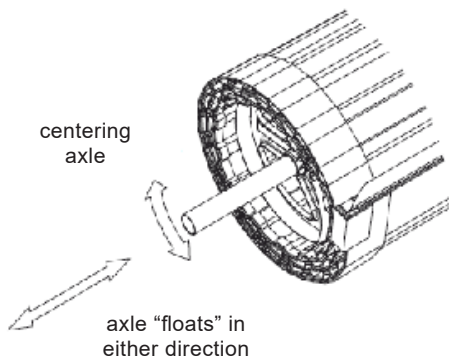

WARNING! practice correct lifting techniques

POSITION DOOR

- Centre the door with the opening, while ensuring the floating axle is also centred with the door. Do this by lining up previous marks with the hub, then lift both the axle and the door together until it is centred with the opening.
- Rotate the curtain and axle so that the bottom rail of the door is positioned as shown (3 o'clock).
- Push the axle forward in the slots (toward the opening) and tighten the nuts firmly without overtightening.

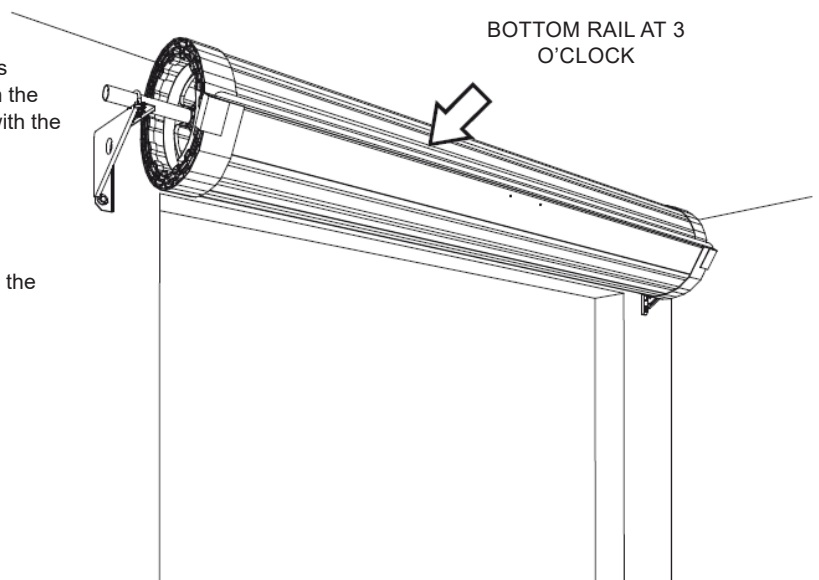

TENSION THE SPRINGS

- Ensure that the bottom rail is at the 3 o'clock position as shown.
- Ensure both "U" bolts are tightened, then rotate door 1½ turns in a forward direction to apply tension. See arrow in image.
- Do not let go as the springs are now tensioned.
- Hold the door firmly, NOW cut the plastic wrap along the bottom rail (taking care not to damage door surface or weatherseal).
- Pull the curtain down slowly and carefully position the wooden chock (or other appropriate stop) as shown. Take care not to damage door surface.

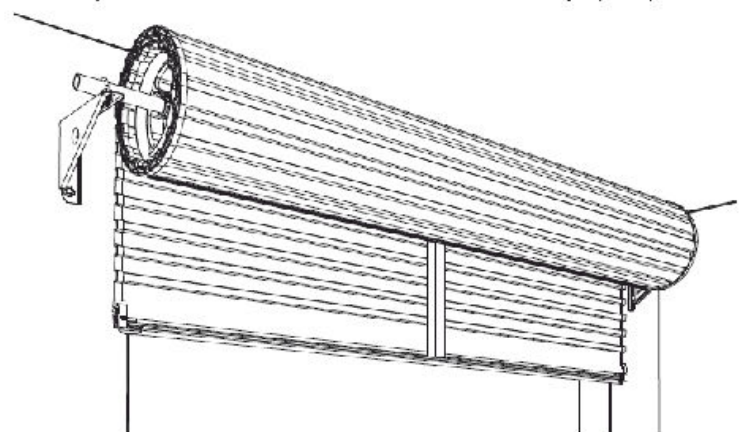
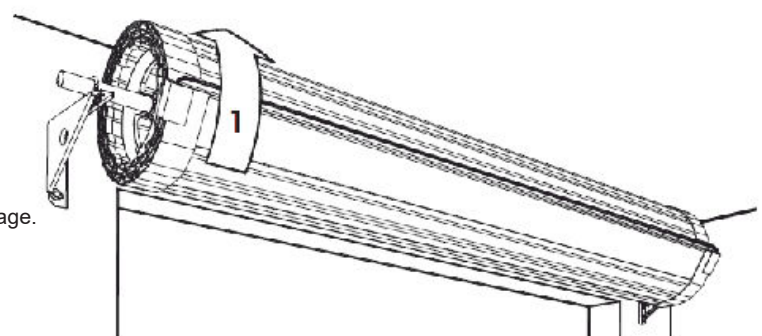

Chock will hold the door until the guides and stops are fitted.

ROLLER DOOR

ATTACHING STOP

To attach bottom rail stops (G) to bottom rail of door.

- Hook stop behind lip in rail, as shown.
- Secure from underneath the rail with screws (G) supplied. Trim the weatherseal flush with the end of the bottom rail.

GUIDES

- Check that curtain overlaps equally on both sides, and cut the guides (C) to the correct length that is, level with the brackets (B)
- Slide four guide clips (E) into each guide (C). Position the bottom clip 200mm from the floor with the rest evenly spaced along the guide.

! tip To prevent clips from sliding down the guide, temporarily secure them with adhesive tape.

- Position one guide over the edge of the door curtain. Mark and drill the top fixed guide clip and secure using 40mm x 8mm coach screw and washer, allowing 3mm clearance between inside of guide and plastic Roll-A-Guide. Ensuring guide is plumb, fix remaining clips. Repeat with 2nd guide.
- Remove the wooden chock and slowly lower the door removing plastic wrap as you pull door down, reposition the guides as necessary to allow smooth and even operation with 0>1mm clearancet.
- Ensure door curtain enters guides smoothly. It will be necessary to adjust the guide lead in to achieve this.

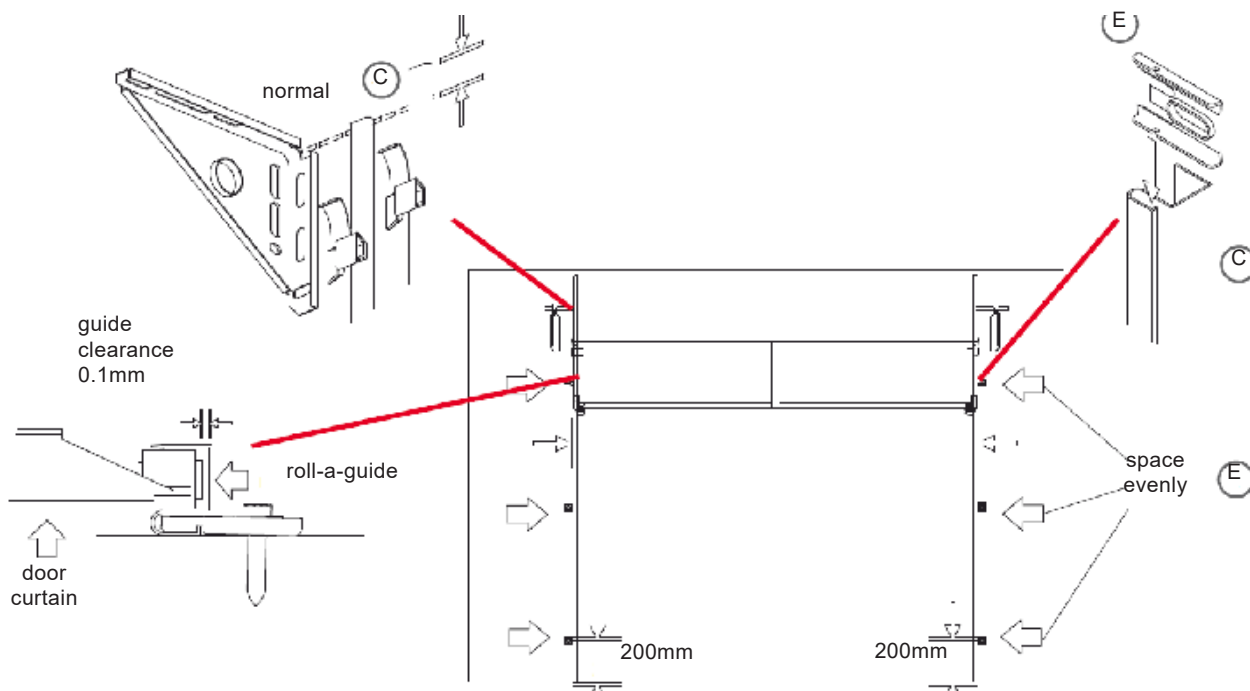
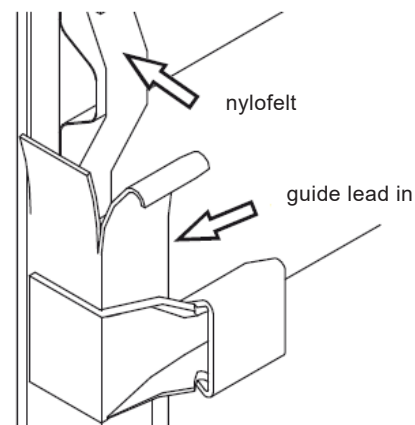
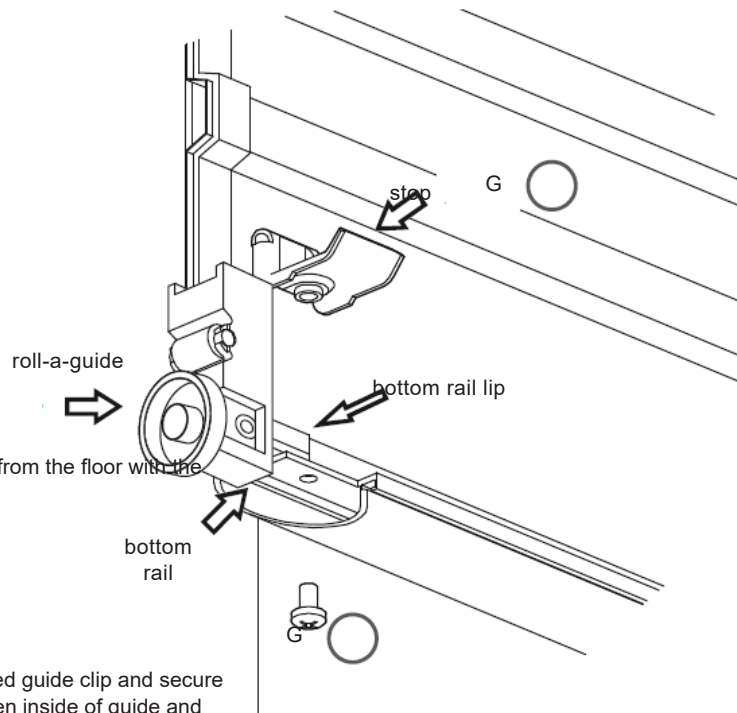

ROLLER DOOR

FITTING HANDLE

- Fit the handle (F) to the outside of the door using the screws (P), nuts and washers provided

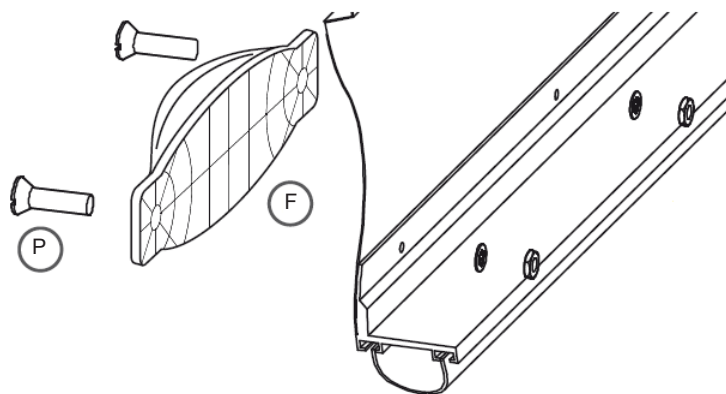

GENTRE LIFT LOCK



LACERATION: Wear appropriate gloves as some edges of the door are very sharp.

- Raise the curtain until the lock corrugation is visible above the door guides.
- Install locking bar retainer (I) in line with lock corrugation by pushing retainer towards door edge, sliding the legs under the Nylofelt® and hooking them over the curtain edge. Ensure lock bar retainers sit squarely on door curtain

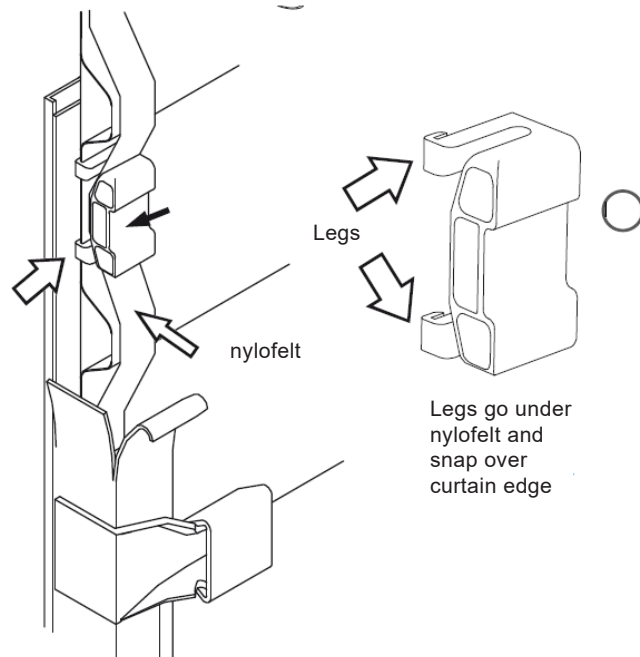

It is easier to hook legs one at a time.

- Fit faceplate (H) to outside of door where the hook will latch onto curtain edge, then slide faceplate as far to the right as possible. Use adhesive tape on outside to hold in position
- Attach the lock body (H) to the faceplate from the inside, using the mounting screws and washers. Do not over tighten the screws.
- With the door in the closed position slide the end of the locking bars through the lockit retainers, and while holding the bars level mark the side of the guides.
- Drill and file out a rectangular slot no longer than 25mm and no wider than 10mm. End remains in line with top of locking bar.
- Slide bars through the guide slot, then back onto lock arms. Screw on securely using screws (O). Ensure that locking bars do not protrude more than 20mm beyond guide in locked position. It may be necessary to adjust the length of the bars.
- Ensure a clean and dry guide surface. Wipe guide with clean rag.
- Peel lining from lock bar cover (J) and position over hole. Check the movement of locking bar is free.

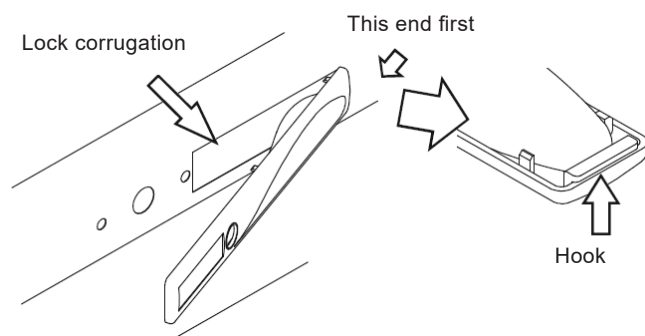

ROLLER DOOR

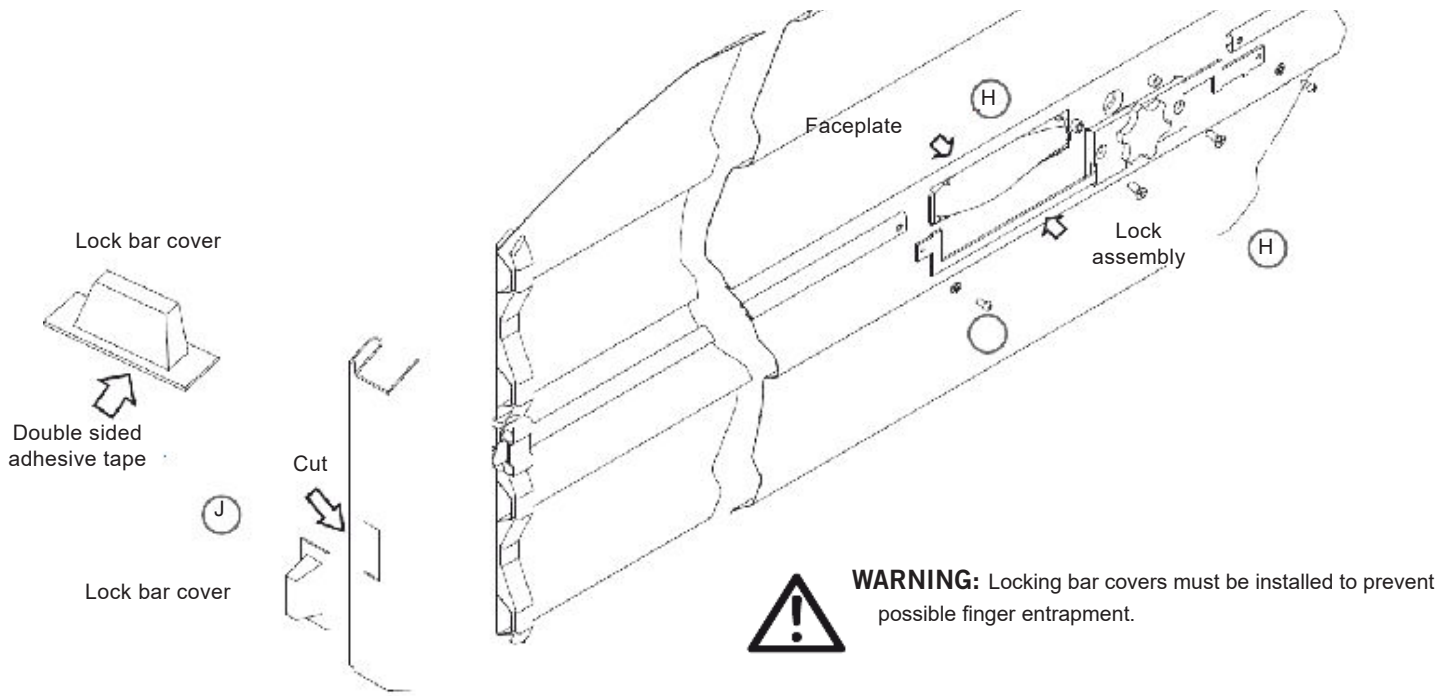

CLEAN UP

- Remove all swarf (drill filings) with a soft brush or rag.
- Hose down roof and walls thoroughly.
- For Coloursteel sheds use touch-up paint provided on all nail heads, rivets and exposed cuts.

ROLLER DOOR

TROUBLESHOOTING

SYMPTOM	POSSIBLE CAUSE	REMEDY
Door is hard to operate in ANY DIRECTION	Door jamming in the guides	Check: a) the guide clearances b) the guides are plumb c) that the guide surfaces are clean and free from oil d) that the locking bars are the correct length e) that the weatherseal is correct length
The door is hard to operate in ONE DIRECTION	The spring tension requires adjustment	a) If the door is hard to lift, but tends to drop, refer to section "centralise the axel when door is mounted" to increase the spring tension b) If the door is hard to close, but tends to rise, refer to section "centralise the axel when door is mounted" to decrease the spring tension
If the door rolls up crooked	Brackets are not level Guides are not plumb Axle is not centred	Make sure brackets are level, refer to section "install second bracket". Make sure the guides are plumb, refer to section "guides". Centralise the axle, refer to section "centralise the axel when door is mounted"

CENTRALISE THE AXEL WHEN DOOR IS MOUNTED



WARNING: Ensure that pipe wrench is fitted correctly to the axle and if it is gripped onto the axle do not underestimate the tension in the spring when undoing the clamps.

CAUTION: THIS ADJUSTMENT REQUIRES 2 PERSONS TO COMPLETE.

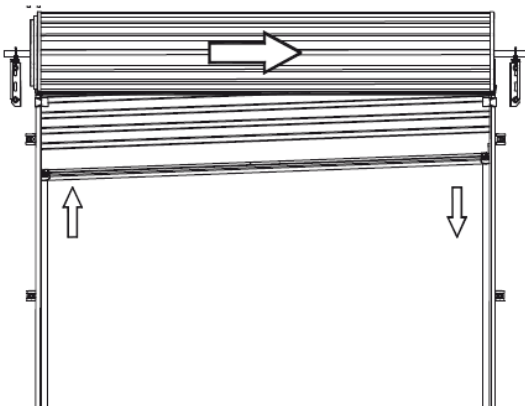

If the door rolls up crooked with the RIGHT HAND SIDE higher than the left proceed as follows:

- Roll the door up as high as possible and tie two ropes around the door roll approximately 300mm from each end, as a safety precaution.
- With a person at each end of the door, hold the axle firmly with a large pip wrench (Stillson) at least 450mm long.
- Loosen the "U" bolt nuts at both ends and KEEP A FIRM GRIP ON WRENCH.
- Move the axle to the RIGHT between 20 - 40mm.
- Re-tighten "U" bolts before releasing pipe wrench.
- Test and repeat if further adjustment in needed.
- If the door is stiff to work or rattles over lead-in on top of guide, then refer to Section "Position door"

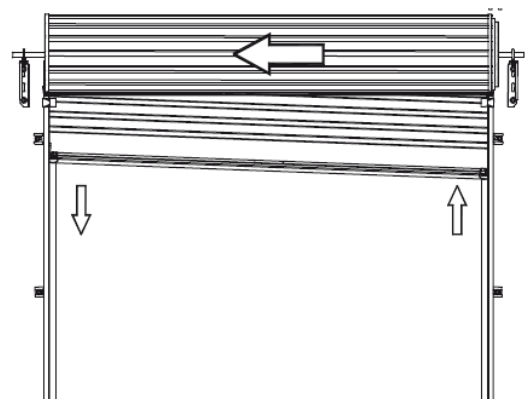

If the door rolls up crooked with the LEFT HAND SIDE higher than the left proceed as follows:

- Roll the door up as high as possible and tie two ropes around the door roll approximately 300mm from each end, as a safety precaution.
- With a person at each end of the door, hold the axle firmly with a large pip wrench (Stillson) at least 450mm long.
- Loosen the "U" bolt nuts at both ends and KEEP A FIRM GRIP ON WRENCH.
- Move the axle to the LEFT between 20 - 40mm.
- Re-tighten "U" bolts before releasing pipe wrench.
- Test and repeat if further adjustment in needed.
- If the door is stiff to work or rattles over lead-in on top of guide, then refer to Section "Position door"

ROLLER DOOR

ADJUST TO SPRING TENSION



WARNING: Ensure that pipe wrench is fitted correctly to the axle and if it is gripped onto the axle do not underestimate the tension in the spring when undoing the clamps.

CAUTION: THIS ADJUSTMENT REQUIRES 2 PERSONS TO COMPLETE.

- a) with the door rolled up tie two ropes around the door roll approximately 300mm from each end, as a safety precaution.
- b) With a person at each end of the door, hold the axle firmly with a large pipe wrench (Stillson) at least 450mm long.
- c) Loosen the "U" bolt nuts at both ends and KEEP A FIRM GRIP ON WRENCH.
- d) Rotate the axle in the required direction (see diagram).
- e) Re-tighten the "U" bolts BEFORE releasing pipe wrench.
- f) Test and repeat if further adjustment is necessary.

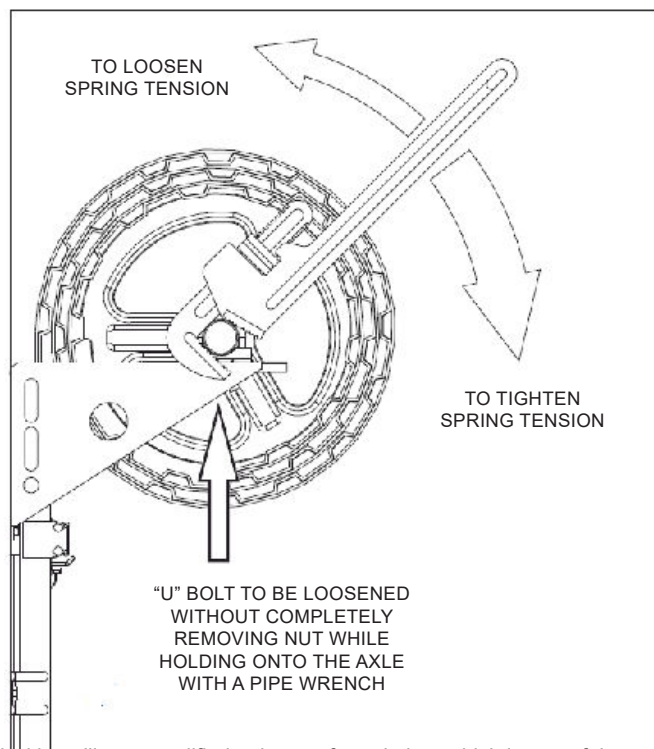

AFTER INSTALLATION CARE

General care of your Roll-A-Door

Cleaning

BLUESCOPE COLORBOND® FINISH Your B&D Roll-A-Door® door has been pre-painted with a silicone modified polyester formulation, which is one of the best paint films commercially available today. However, all exposed surfaces require some attention to guard against the premature onset of corrosion and any other harmful atmospheric effects. In our atmosphere there are harmful deposits that gather on the door surface and if not removed regularly, will seriously affect the appearance and life of the door.

Washing of the door with clean water and a cloth every 14 days is recommended – particular care should be taken to clean areas of the door not normally washed by rain, including the top of the door roll inside the garage.

NOTE: In locations where there is likely to be salt in the air or industrial fallout is severe, more frequent washing is advisable and additional protection of the surface maybe required.

Touch-up paint, if required, is available from your B&D dealer.

Lock

Your lock does not require special maintenance, however, if the keyway becomes stiff, the application of powdered graphite is recommended – do not grease or oil the lock. The faceplate should be washed with soapy water and rinsed well. Strong solvents, such as acetone, should not be used – these will damage the surface. **WARNING!** Do not disassemble the lock mechanism.

When opening the door, always make sure the key is with drawn from the lock – if this is not done, the lock mechanism could be damaged and the key bent or broken.

ROLLER DOOR

We suggest you record your full Key letter and Number on the front of this manual and if replacement keys are required they can be obtained from your nearest B&D office, simply by quoting this number. If the keys have been lost and the number not recorded, it can be found stamped into the locking arm at the back of the mechanism.

NYLOFELT® On no account should you use grease or oil in the door guides or on the Nylofelt® running strips – the grease or oil will clog the Nylofelt® and spoil the operation of the door. An occasional wipe with a cloth dampened with mineral turps or methylated spirits, down the inside of each guide, is very beneficial in removing any trace of grease or dirt.

After the guides have been cleaned, a silicon spray may be used in the guides.

NOTE: WD40 or similar oil based sprays are not silicon and should not be used.

Care should be taken not to damage the Nylofelt®, however, if Nylofelt® is cut or damaged, a lighted match should be used to quickly seal the ends of the nylon braiding, so as to stop any further deterioration.

Regular maintenance required

B&D recommends that you check the operation of your Roll-A-Door® at least every six months (more regularly in extreme environments or frequent use). The effort required to manually open and to manually close the door should be about the same (if door has an automatic opener, put into manual mode before testing door). If the door is difficult to operate in either direction (up or down) then check:

- 1) that the Nylofelt® running strips on each side of the door have not slipped from the edge and are jamming the door;
- 2) that the door is running correctly in the guides and the guides are straight and perpendicular; and
- 3) that the inside surfaces of the guides are clean and free of obstructions. (see paragraph on care of Nylofelt®)

If you have checked these (and corrected where necessary) and the door is still difficult to operate, then your door will need a service to adjust the spring tension and possibly other operational parts of the door. This service should only be carried out by an experienced door technician, using the correct tools.

If you have an automatic opener fitted to your door, it is particularly important that you ensure the optimum operation of the door, otherwise you may reduce the effective life of the opener.

To keep your door running well, it is recommended that your door be serviced, by an experienced door technician, every 12 months (more regularly in extreme environments or frequent use), or earlier if required.

Spring tension

It is natural for springs to lose tension over time. When spring tension is adjusted or when your door is first installed it is usual to apply a little more tension than is required for balanced operation, to allow for the normal "settling in" of the springs.

Duratuf Lifestyle shed Triple Warranty

1. Duratuf warrants that their Lifestyle sheds will be free from manufacturing defects for **30 years**. This warranty also covers components which are missing or damaged at time of despatch from the factory.
2. Duratuf warrants the durability of the structural framing for **30 years**.
3. Duratuf warrants that the metal roofing and wall cladding will not perforate due to corrosion within the following periods:
 - Standard Non-Coastal Warranty – **30 years** if located greater than 2,000m from saltwater, or **15 years** if located between 1,000m and 2,000m from saltwater.
 - With Coastal Upgrade Option – **30 years** if located greater than 1,000m from saltwater, or **15 years** if located between 500m and 1,000m from saltwater.

WARRANTY TERMS AND CONDITIONS

- The warranty is not transferrable and only valid for the original purchaser. Proof of purchase and proof of damage or defect is required to submit a claim. Warranty periods begin at the date of manufacture.
- This warranty is in addition to your rights under New Zealand consumer law and must be registered within 90 days from purchase to be valid. Refer to the warranty registration guidance below. All claims must be made in writing within 30 days of discovery. Interference with the product or other action taken to remedy a defect prior to Duratuf being notified of the suspected defect and Duratuf being given a reasonable time to inspect the product in situ will invalidate a claim.
- For the warranty to be valid, the recommendations in our **Kitset Care Guide** <https://www.duratuf.co.nz/kitset-care-guide/> and the **Assembly Care Instructions** given in the Assembly Instruction booklet must be followed; and the **Minimum Maintenance** in accordance with instructions below must be performed for the life of the product.
- Except as provided otherwise by NZ consumer law, the liability of Duratuf is limited to replacing or repairing any defective or missing product. Any repaired or replaced material will be covered only by the balance of the original warranty period. Duratuf will not be liable for any consequential loss or damage, or labour costs. Transport charges will apply to our nearest reseller only.
- The structural framing and cladding warranties are subject to the shed being installed on a level concrete base, or other solid supports, at least 40mm above ground level, and contact being prevented at all times with soil, vegetation, organic matter, fertilizers, or other moisture retaining substances.
- In the rare event of a claim and upon receiving proof of purchase and defect, Duratuf will at its option repair or replace defective parts, or provide a prorated refund for the remaining life of the applicable warranty. Any replacement product provided will be covered by the Warranty for the balance of the Warranty term as if the replaced product were the original product.
- Duratuf reserves the right to inspect the shed in situ at the installation site and to conduct tests at any time after a Warranty claim is received. Any interference with the shed prior to inspection by Duratuf may void a claim under this Warranty.
- Any product replaced under this Warranty becomes the property of Duratuf.
- Any failure, delay, or indulgence by Duratuf will not operate as a waiver. A waiver by Duratuf of any condition of this Warranty is not a waiver of any other condition. No waiver is effective unless it is in writing.
- All terms, conditions, warranties, undertakings, inducements, and representations other than contained in this warranty, whether express or implied, statutory, or otherwise, are expressly excluded.
- This Warranty does not exclude, restrict, or modify any liability that cannot be excluded, restricted, or modified at law.

EXCLUSIONS FROM WARRANTY COVER

- Normal wear and tear. Fading, chalking, or discolouration of the cladding. Minor white corrosion at cuts or bends.
- Cladding perforation in areas where severe or very severe environmental situations are extended inland by local conditions.
- Timber floors less than 40mm above ground level, or where used for storage of other than normal lightweight household items.
- This warranty will not apply if the failure or defect is caused or contributed to by an event or action beyond the reasonable control of Duratuf, including without limitation:
 - Mechanical, chemical, or other damage sustained after despatch from Duratuf's factory.
 - Problems resulting from misuse or use for purposes other than normal dry storage use.
 - Fire, flood, storm, cyclone, earthquake or other 'Acts of God.'

MINIMUM MAINTENANCE REQUIREMENTS

- All metal swarf must be cleaned off the shed IMMEDIATELY.
- Wash all external surfaces using a soft nylon brush with water every 12 months, or for locations within 2 km of saltwater, wash every 3 months. After a storm, wash the cladding and the gutters as soon as possible to remove any salt deposits.
- A low-pressure water spray may also be used, less than 10 MPa (1500 psi or 100 Bar).
- Outdoor cleaning detergents may be used if they do not contain bleach, chlorine, or other harmful chemicals.
- Volcanic ash fallout and pollen deposits—wash as soon as possible, removing all deposits from roof and gutters.
- Gutters and channels to be kept clear of leaves and dirt at all times.
- Remove any lichen or mould: First wash off any loose growth with a brush and water. Apply diluted bleach (sodium hypochlorite) at 2% solution. A small amount of household detergent (no more than 5-7 ml per litre of water) may be added to the solution to improve wetting. Leave for 5 minutes. Wash down with copious amounts of clean water.
- Remove and replace any fasteners, washers, or fittings showing signs of corrosion.

Warranty registration

Go to <https://duratuf.co.nz/warranty> to register the Warranty within 90 days of purchase. Alternatively, call us on 0800 438 274. It is important to keep your proof of purchase as it will be required in the unlikely event of a claim. Many thanks, from the team at Duratuf.

Thank you for investing in a Duratuf Lifestyle Range Shed.

